

# Trails West®

---

## Trails West Owners Manual

### Table of Contents

Towing A Trailer .....	Page 2
Tow Vehicle .....	Page 3
Coupling Your Trailer to Your Tow Vehicle .....	Page 4
Loading Your Trailer .....	Page 7
Tires .....	Page 8
Pre-Towing Checklist .....	Page 11
New Trailer Break-In .....	Page 11
Un-Coupling Your Trailer From Your Tow Vehicle .....	Page 11
Accessories .....	Page 12
Maintenance .....	Page 13
Glossary of Tire Terminology .....	Page 16

# Trails West®

---

Thank you for purchasing a Trails West Product. You are now the owner of one of the finest trailers of this type on the market today. In order for you to get the maximum pleasure and utility from your trailer, we would like to make you aware of the following information.

## Towing a Trailer

Towing a trailer can be safe and easy if done properly. It is important to realize that your tow vehicle will handle and respond differently when pulling a trailer. If you are new to pulling trailers, it is best to find a large open area, free from traffic, obstacles or other distractions, to acquaint yourself with these differences prior to towing your trailer on the open road. As you become acquainted with towing your trailer, here are a few recommendations and items to be aware of:

- **Acceleration and Stopping Distance** – Due to the added demands of pulling a trailer, you will notice reduced acceleration and increased stopping distances.
- **Following Distance** – As a result of increased stopping distances, while towing a trailer, you should substantially increase the distance between your vehicle and those you follow.
- **Passing** – Because of reduced acceleration and an increase in overall length, you will need more distance to pass slower moving vehicles.
- **Turning** – Make wider turns than normal as to not hit curbs, signs, gates, cement pylons etc. with your trailer. Avoid turning too sharply. With bumper pull models, this can cause the bumper of your tow vehicle to hit the front of your trailer. With gooseneck models, this can cause the front of the trailer to hit the rear of your tow vehicle's cab. Extremely sharp turns can also be detrimental to axle components and tires.
- **Mirrors** – Check your rear view mirrors more often, observing your trailer and traffic.
- **Height Clearance** – Be aware that your trailer is most likely taller than your tow vehicle. Use caution when pulling your trailer under objects (i.e. trees, covered parking areas, car washes, covered gas station filling areas etc.).
- **Adverse Road Conditions** – Be aware that any adverse road condition will only be amplified by towing a trailer. Use extreme caution when pulling your trailer under such conditions.
- **Descending Grades** – Slow down and shift your tow vehicle into a lower gear before starting down a long or steep grade. Failure to do so may cause both trailer and tow vehicle brakes to over-heat and become less effective.
- **Speed** – As a general rule, you should drive slower when pulling a trailer than you may normally drive.
- **Trailer sway** – Your trailer may sway under the following conditions: excess speed, depressions or bumps in the road, passing an oncoming bus or semi or rounding a corner with excessive speed. If your trailer starts to sway, a short, light, manual application of the trailer brakes only, or accelerating the vehicle for a short distance will stop the swaying.

# Trails West®

---

The above list does not include all scenarios or situations you may encounter while towing your trailer. Our intent is to make you aware of some general guidelines of trailer towing.

## Tow Vehicle

It is important to note that easy and safe trailering requires a vehicle that is properly equipped. Such equipment includes a vehicle with an adequate weight rating, hitch, electrical connection, and an electric brake control.

## **Tow Vehicle Weight Rating**

Vehicles manufactured to tow trailers are designed to meet certain specifications with regard to the amount of weight they can safely tow. These specifications pertain to items such as engine horsepower and torque, axle ratio, and suspension. Before towing your trailer for the first time, it is important to determine the amount of weight your vehicle can safely tow. In addition, it is important to know how much weight your vehicle can support at the hitch. This is referred to as “hitch” or “tongue” weight. Specifications regarding towing and hitch weights can be found in most vehicle owner’s manuals. If it cannot be found there, contact the dealer from which you purchased your tow vehicle.

Next you must determine the total weight and tongue weight of your trailer. The weight of your trailer is determined by using the Gross Vehicle Weight Rating (GVWR) indicated on the VIN tag located on the left side of your trailer. **The GVWR is what your trailer weighs when loaded to its’ maximum capacity (i.e. this is the most your trailer can weigh without being overloaded). The GVWR is not what your trailer weighs when empty nor is it the amount of weight that can be loaded into it.** The tongue weight of your trailer is approximately 12% to 15% of the GVWR if it’s a bumper pull model or approximately 25% of the GVWR if it’s a gooseneck model. Once these weights are established, match them to the specifications of your tow vehicle to determine if it is rated to safely tow your trailer.

## **Hitch**

Hitches are rated by the amount of weight they can tow and tongue weight they can support. **It is important that the hitch on your tow vehicle is rated equal to or greater than the GVWR of your trailer.** If you are unsure of the rating of your hitch, these specifications are often located on the hitch itself. If you cannot locate, or do not know the specifications of your hitch, consult your vehicle dealer or hitch distributor.

Along with the correct hitch, it is equally important to have the correct size and properly rated ball on your hitch. All Trails West trailers require a 2 5/16”, class 4 ball. If you are unsure of the size and rating of the ball, it is usually stamped on the top of the ball. **NOTE: The ball must be rated equal to or greater than the GVWR of your trailer.**

# Trails West®

---

## **Electrical Connection**

In order for the electrical system on your trailer to operate, your tow vehicle must be equipped with an electrical connection that is compatible with your trailer. All Trails West trailers utilize a 7 circuit RV type connector. Included with this user's manual, is a diagram depicting how this electrical connection is wired. If your tow vehicle's electrical connection is not compatible with your trailer's connection, or you are unsure if it is compatible, consult your dealer or the dealer from which you purchased your tow vehicle. **Do not attempt to tow your trailer without having a compatible wiring connection on your tow vehicle.**

## **Electric Brake Control**

Your trailer is equipped with electric brakes at each wheel. To activate your trailer brakes, an electric brake control must be installed in your tow vehicle. In most cases these can be purchased from, and installed by your dealer. Follow the instructions for use, set up and maintenance specified by the brake control manufacturer. **Do not attempt to tow your trailer without a properly functioning electric brake control.**

## **Coupling your Trailer to your Tow Vehicle**

Before coupling your trailer to your tow vehicle the following steps should be followed:

- Inspect the ball and coupler (inside and out) for signs of excess wear or damage.
- Insure that the coupler and ball are the same size.
- Lubricate the ball and inside of the coupler with a thin layer of grease to reduce friction and excess wear.
- Inspect your hitch, making certain it is fastened securely to your tow vehicle and that the ball is securely mounted to the hitch.

If, during your inspection, problems are found, do not proceed with coupling to your vehicle and pulling your trailer. Have any problem(s) corrected prior to towing your trailer. If no problems are found, with the coupler in the "open" position, proceed by lowering the trailer coupler onto the hitch ball. Lower the coupler until the tow vehicle carries the full tongue weight of the trailer. If your trailer is a bumper pull model, close the coupler, making sure the collar slides all the way forward, and install the safety pin through the coupler handle. If your trailer is an Adventure model, close the coupler by pushing the release handle down until it latches then install the safety pin through the handle. If your trailer is a gooseneck model, close the coupler by sliding the locking plate on the bottom of the coupler until the hole in the plate is aligned with the pin on the spring loaded handle, then drop the pin into the hole in the locking plate. Regardless of your coupler type, insure the connection is secure by raising the tongue of the trailer with the jack while the coupler is in the closed position. **If the coupler comes off the hitch ball, do not pull your trailer.**

# Trails West®

---

Check the following:

- Is the coupler completely closed?
- Is the hitch ball size 2 5/16"?
- Is the ball or coupler damaged or worn excessively?

If you cannot determine the problem, or don't feel comfortable inspecting your coupler and hitch, contact your dealer. If the coupler does not come off the ball, lower the tongue of the trailer allowing the tow vehicle to support the trailer's total tongue weight. Insure that the jack is fully retracted and dolly wheel (if equipped) is removed prior to moving your trailer. If your trailer is a gooseneck model, in addition to retracting the jack, the foot of the jack must be retracted as well. This is done by pulling the release pin on the left side of the jack leg and raising the foot with the provided handle. In addition, the gooseneck jack handle must be removed from the socket on the side of the trailer and stowed prior to moving your trailer.

## Safety Chains

Your trailer is equipped with two safety chains. In the event of a coupler or hitch failure, these are designed to retain the connection between the trailer and tow vehicle. Before each trip, inspect the chains and hooks for wear or damage and replace if necessary. Connect the chains to your hitch (if equipped with safety chain attachment points) or a frame member of your tow vehicle. **Do not connect them to the ball, ball mount or other interchangeable component of your hitch.** When connecting the safety chains insure that you leave enough slack to turn freely but not so much slack to allow the chains to drag along the ground. If your trailer is a bumper pull model, the safety chains must cross under the coupler of your trailer when connected to your tow vehicle. By crossing the chains a cradle is created that will hold the coupler off the ground in the event your coupler or hitch fail.

## Breakaway Brake System

Your trailer is equipped with a system that activates the trailer brakes automatically if the trailer becomes completely separated from your tow vehicle. This system consists of a switch (complete with pull pin and actuating cable) mounted to the trailer near the coupler, and a gel cell battery, located in the tack/dressing room, that provides power to the switch. (If your trailer is a living quarters trailer or is equipped with an on board 12 volt battery to operate interior and exterior lights, the break away switch is powered by this battery and is not equipped with a separate gel cell battery), It is recommended that the breakaway system be tested prior to each trip. **NOTE: prior to testing your breakaway system, make sure the main trailer electrical connection is not plugged into the tow vehicle. Damage to your electronic brake control will occur if the trailer is connected to the vehicle while testing the system.** To test the breakaway system, remove the pull pin from the switch, then pull the trailer ahead slowly (5mph or less). You should feel a resistance from the trailer indicating that the trailer brakes have been activated. Once you are satisfied that the brakes have been activated, bring the tow vehicle and trailer to a complete stop and reinstall the pull pin.

# Trails West®

---

For the breakaway system to operate correctly, the cord attached to the pull pin must be secured to the tow vehicle. **Do not attach the cord to the ball, ball mount, or any part of the safety chain.** Leave enough slack in the cord so the pull pin will activate the switch only when complete separation from the tow vehicle occurs. This would include failure and disengagement of **both** the hitch and safety chains.

Do not attempt to pull the trailer with the pull pin removed from the switch, use the break away brake system as a parking brake, or leave the system activated for extended periods. Such use will cause damage to components of your trailer brake system not covered by your warranty. During long periods of storage or non-use, the battery should be removed and stored indoors. The provided gel cell or 12 volt battery must be charged periodically.

## Electrical Connection

Your trailer is equipped with a 12-volt electrical system that operates the lights and brakes. Power is supplied to these systems via a connection between the trailer and tow vehicle. Prior to each trip the following should be checked for proper operation:

- Insure the connection between your tow vehicle and trailer are secure (the cover on the tow vehicle connection should engage the trailer connection as to not allow them to disconnect during transit).
- Clearance and running lights (turn on tow vehicle headlights).
- Brake lights (depress tow vehicle brake pedal).
- Turn signals (use tow vehicle turn signal lever).
- Reverse lights (place tow vehicle in reverse). It requires a second person to check reverse lights. Not all models are equipped with reverse lights.
- Electric brake system (test per your brake control manufacturer's procedure).

If you find any problems with your electrical system, have it inspected and repaired by your local dealer as soon as possible.

Your trailer is equipped with interior lights in both the livestock and tack compartments. Your trailer may also be equipped with optional exterior loading lights. These interior and exterior lights run off a "hot wire" circuit (a direct circuit between the tow vehicle battery and tow vehicle electrical connection). **NOTE: not all tow vehicles are equipped with a hot wire circuit. If your interior and exterior load lights do not work, have your tow vehicle inspected to determine if it is equipped with a hot wire circuit.** In order for these lights to operate, your trailer must be connected to your tow vehicle's electrical connection. Your trailer may also be pre-wired for use of an onboard battery to power these lights. If this is the case, and the onboard battery is fully charged, it is unnecessary to have your trailer connected to the tow vehicle to operate the lights.

# Trails West®

---

## Loading Your Trailer

Your trailer has been engineered and designed to safely and conveniently haul tack equipment and/or livestock. It is not recommended that your trailer be used for any other purpose.

**Before attempting to load your trailer, make sure it is securely coupled to your tow vehicle.** To load your trailer safely and correctly, caution must be taken not to exceed the GVWR of the trailer (GVWR is total weight of trailer when loaded to maximum capacity and is indicated on the VIN tag on the left side of your trailer). To determine if you are within the GVWR of your trailer you must know the following: GVWR of your trailer (this is found on VIN tag on left side of trailer), the weight of your trailer when empty, and the weight of your intended load. If you have difficulty determining the GVWR or empty weight of your trailer, contact your dealer for assistance. The total allowable load for your trailer is calculated by subtracting the empty trailer weight from the GVWR. As an example: if the GVWR of your trailer is 7910 lbs., and the empty weight of your trailer is 3500 lbs., then the maximum load your trailer is rated to haul is 4410 lbs. The maximum amount of cargo your trailer can safely carry is indicated on the Tire and Loading Information placard located on the left side of your trailer near the vehicle identification tag.

Another factor important to safely loading and transporting your trailer is the distribution of the intended load within the trailer. Your trailer is designed in such a way that the axles carry the majority of the load weight. In addition, your trailer is designed to transfer a portion of the load weight to the hitch of your tow vehicle in the form of tongue weight. The distribution of the load inside your trailer can adversely affect the tongue weight. Ideally, the load in your trailer should be centered over the axles. If the entire load cannot be centered over the axles, it is essential to have the load equally distributed in front of and behind the axles. Having too much weight in front of the axles increases tongue weight, thus increasing the amount of weight on the hitch and rear wheels of the tow vehicle. This causes the front wheels of the tow vehicle to become too lightly loaded. Having too much weight behind the axles decreases tongue weight and can exert an upward pull on the rear of the tow vehicle. Either of these situations can cause the trailer and/or tow vehicle to become unstable, possibly causing a loss of control while towing.

After your trailer is loaded, insure that all dividers (slant load horse trailers), cross gates (stock trailers), doors and drop down feed doors (if equipped) are closed and properly secured. Dividers, doors or cross gates that are not properly closed and secured may cause harm to livestock and/or damage trailer walls, dividers, cross gates, door and gate hinges, or latching mechanisms. Such damage is not covered by your warranty.

Before leaving on your first trip, make sure your trailer is level when coupled to your tow vehicle. This will insure that each axle is carrying an equal portion of the load. With bumper pull models, as a rule of thumb, the top of your hitch ball should be approximately 19" from the ground before your trailer is lowered onto it. If your trailer is an Adventure model, the top of

# Trails West®

---

your hitch ball should be approximately 18" from the ground before your trailer is lowered onto it. On gooseneck models, the trailer is leveled by raising or lowering the front of the trailer. This is done by: 1- Closing the coupler on the ball of your tow vehicle, 2- Lowering the jack foot until it rests on the ground, 3- Loosening the bolt on the front of the coupler tube, 4- Removing the pin from the coupler tube, 5- Raising or lowering the front of the trailer using the trailer jack, 6- Re-install the coupler tube pin, 7- Re-tighten the bolt and lock nut on the front of the coupler tube. If your trailer is not level when pulled, premature wear of tires and/or axle components may occur. Such wear is not covered by warranty.

## **Tires**

Your trailer is equipped with quality tires that were designed for use on trailers. For your tires to accomplish their purpose there are a few things you need to be aware of.

Tires, like the other components of your trailer, require maintenance. An important part of tire maintenance is insuring that each tire is adequately inflated. Air pressure is what provides tires with their load carrying capability. The tires on your trailer have been assigned a recommended cold inflation pressure. This recommendation can be found on the Tire sidewall and/or on the Loading Information placard located on the left side of the trailer near the vehicle identification tag and is referred to as "cold tire pressure". Cold tire pressure can only be measured when your trailer has been sitting for a minimum of 3 hours because tires warm up as they are used. This warming causes the air inside the tires to expand thus increasing tire pressure. If measured under these circumstances, it is impossible to get an accurate cold inflation measurement. Because most tires naturally lose air over time or when a pothole or curb is struck, we recommend the cold inflation pressure be checked at least once per month and before leaving on long trips. If you have been pulling your trailer and find a tire that is under inflated, fill the tire to the recommended cold pressure. Realize that this tire may still be slightly under inflated requiring you to obtain a cold pressure measurement after the tire has cooled and adjust the tire pressure again.

Tire pressure can be measured using a tire pressure gauge. These gauges are readily available at tire and auto parts stores. If, after checking the air pressure, you find it to be lower or higher than the recommended level, the air pressure must be adjusted. If the air pressure is lower than the recommended level, add air using a compressed air source. If the air pressure is higher than the recommended level, release air by depressing the valve stem.

It is important to realize that improper tire inflation can be detrimental to tires. Improper inflation causes uneven tire wear and can cause a tire to fail completely. Tire failure can lead to an unsafe situation possibly causing you to lose control of your trailer and tow vehicle. In addition to inflation, visually inspect your trailer's tires before each trip. Look for abnormal tread wear, bulges, cracks, cuts, or other damage.

# Trails West®

You must realize that trailer tires, denoted as "ST" tires (i.e. **ST225/75R15**), have a speed rating of between 62 and 68 miles per hour. This rating indicates the speed at which a tire is designed to be used for extended periods of time. The "ST" designation can be found on the side wall of tires at the beginning of the tire size (see side wall diagram below -ST will replace LT designation). Failure to operate your trailer within the tire's speed rating creates a potential for tire failure. Tire failure at high speed may cause an unsafe driving condition and possibly damage your trailer.

If the need arises, purchase replacement tires that are compatible to the tire you are replacing. Information regarding size and capacities can be found on the Tire and Loading Information placard or on the sidewall of the tire. Information found on the sidewall of a tire includes:

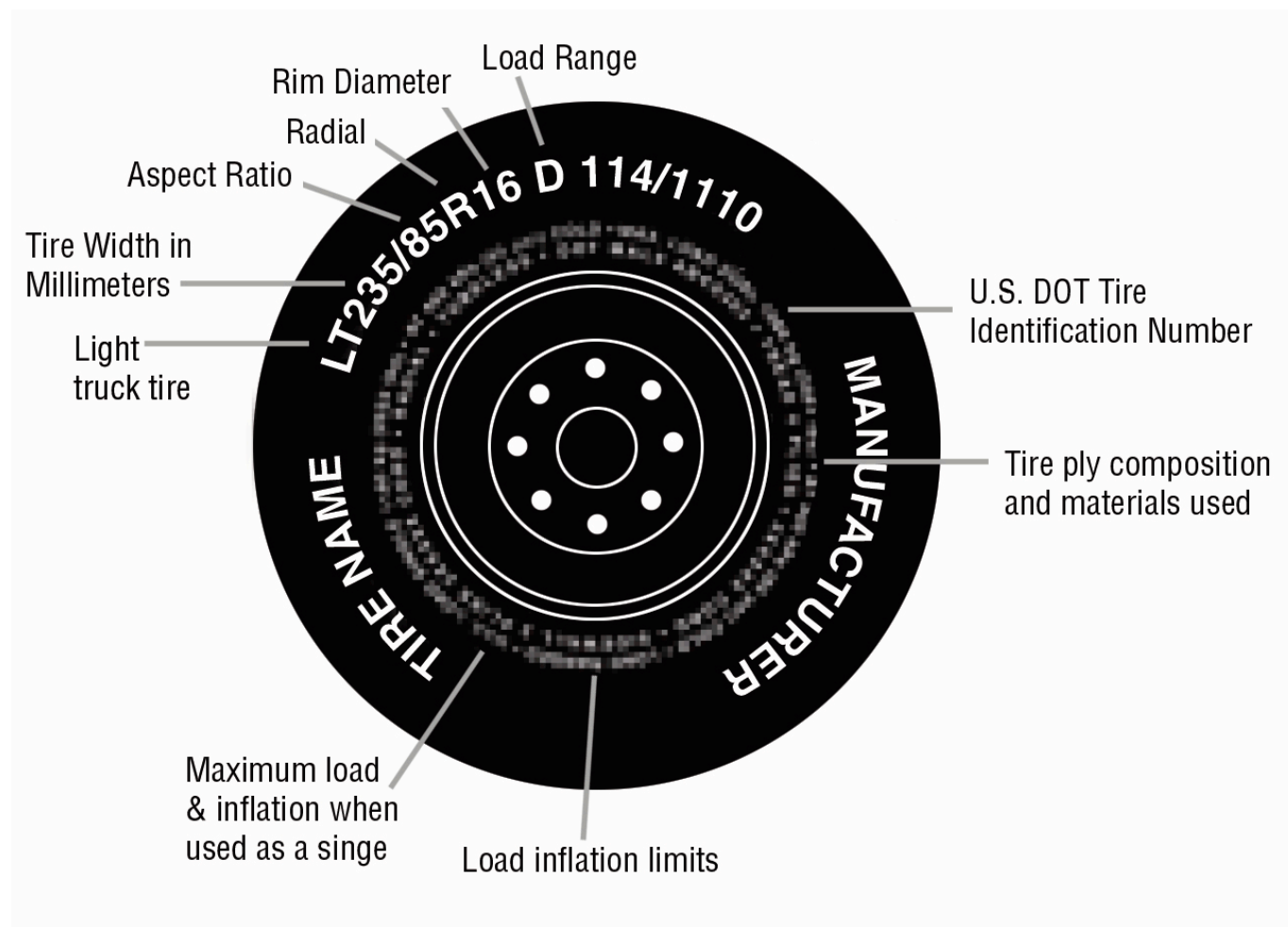

# Trails West®

---

## **ST or LT**

The "ST" indicates the tire is for trailer use only, the "LT" indicates the tire is for light trucks.

## **Tire Width**

This three-digit number gives the width in millimeters of the tire from sidewall edge to sidewall edge. In general, the larger the number, the wider the tire.

## **Aspect Ratio**

This two-digit number, known as the aspect ratio, gives the tire's ratio of height to width.

## **R**

The "R" indicates the tire is a radial tire.

## **Rim Diameter**

This two-digit number is the wheel or rim diameter in inches. If you change your wheel size, you will have to purchase new tires to match the new wheel diameter.

## **U.S. DOT Tire Identification Number**

This number begins with the letters "DOT" and indicates that the tire meets all federal standards. The next two numbers or letters are the plant code where it was manufactured, and the last four numbers represent the week and year the tire was manufactured. For example, the numbers 3197 means the 31<sup>st</sup> week of 1997. The other numbers are marketing codes used at the manufacturer's discretion. This information is used to contact consumers if a tire defect requires a recall.

## **Tire Ply Composition and Material Used**

The number of plies indicates the number of layers of rubber-coated fabric in the tire. In general, the greater the number of plies, the more weight a tire can support. Tire manufacturers also must indicate the material in the tire, which include steel, nylon, polyester, and others.

## **Maximum Load Rating**

This number indicates the maximum load in kilograms and pounds that can be carried by the tire.

## **Maximum Permissible Inflation Pressure**

This number is the greatest amount of air pressure that should ever be put into the tire under normal driving conditions.

## **Load Range**

This information identifies the tire's load carrying capabilities and its inflation limits.

For a complete list of tire terminology see the Glossary of Tire Terminology at the end of this guide.

# Trails West®

---

## Pre-Towing Checklist

Prior to each trip and periodically during each trip check the following:

- Insure that tires are inflated per the tire manufacture's specifications located on the sidewall of each tire. Inspect wheels for damage.
- Insure that all lug nuts are properly torqued to 120 or 140 ft. lbs. (see new trailer break in section for torque specifics and axle size).
- Insure that the coupler is properly closed.
- Insure that the safety chains are properly connected to tow vehicle.
- Insure that the breakaway brake system cable is properly attached to tow vehicle and the breakaway brake system operates properly.
- Insure that the electrical connection is secure and all lights and trailer brakes are working properly.
- Insure that all doors, gates and windows are closed and properly latched.
- Insure that your cargo is properly secured.

## New Trailer Break - In

Your new trailer as a whole requires very little break-in. However, there are some components on your trailer that will require attention during the first trip(s). Lug nuts on new wheels tend to loosen as paint under the lug nut shoulder wears away. After the first 10, 25, and 50 miles of road service, lug nuts on all wheel types should be re-torqued to 120 ft. lbs. (If your trailer is equipped with 8000# axles (9/16" wheel studs), lug nuts should be re-torqued to 140 ft. lbs.) Regardless of wheel type or axle size, all lug nuts should be re-torqued periodically thereafter. Initially the brake shoes on your trailer wear rapidly. Therefore, they must be adjusted following the first 200 miles of service. The brakes on your trailer are not self-adjusting and must be adjusted manually. If you are not familiar with this procedure, arrange to have your dealer adjust your brakes or explain how to adjust them so you can perform the work yourself.

## Un-Coupling your Trailer from your Tow Vehicle

The first step in un-coupling your trailer from your tow vehicle is finding a location where the ground is level. **Failure to un-couple your trailer on level ground may cause the trailer to roll once removed from the tow vehicle, causing personal injury and/or property damage.** Next chock the trailer wheels, both front and rear, to prevent the trailer from rolling. Disconnect the electrical connection, safety chains and break away switch cable from your tow vehicle. Then, open the coupler and, using the trailer jack, raise the trailer off the hitch ball.

# Trails West®

---

## Accessories

Your trailer may be equipped with one or more of the following optional accessories. If your trailer is equipped with an accessory that is not listed here, contact your dealer with any questions regarding its operation.

### **Roof Mounted Hay Rack with Ladder**

If used correctly, roof mounted hay racks can be an easy way to transport hay or straw. Your hay rack is designed to carry 500 lbs., or approximately 5 bales of hay. Exceeding these limits will damage your hay rack and possibly your trailer's roof. **Prior to moving your trailer, make sure the hay or straw is properly secured to the hay rack. The hay rack is designed for hauling hay or straw and should not be used for any other purpose.** Extreme caution should be used while loading or unloading your hayrack. Anytime you are on the roof of your trailer be aware of your surroundings. Failure to do so may cause you to trip and/or fall from the trailer. **Do not use your hayrack as an observation platform or occupy it while the trailer is moving.**

### **Corner Mounted Water Tank**

This tank is located in the right rear corner of your tack or dressing room and holds approximately 20 gallons. The tank is equipped with a valve and hose. Fill the tank by attaching a garden hose to the end of the tank hose, open the valve on the bottom of the tank, and back fill. *NOTE: if the tank is not completely empty, the valve must remain closed until the garden hose is attached.* Once the tank is filled, **close** the valve and remove the garden hose. To empty the tank, open the valve to dispense water. **The water in this tank is not intended for human consumption.**

### **Hot Wire Package**

The hot wire package comes complete with wiring to a 12-volt battery location and box. The trailer is wired in such a way as to allow operation of all interior lights and exterior loading lights (if equipped) without being plugged into the tow vehicle's electrical system. The wire connected to the positive terminal of the battery is equipped with a 30 amp, in line fuse to protect the wiring in your trailer. **NOTE: in some cases a 12-volt battery and box are not included with the hot wire package. If your hot wire package was not equipped with a battery and battery box, this must be purchased separately. Ask your dealer for details.** This package is wired to allow the battery to be charged by your tow vehicle's electrical system while you pull your trailer. However, due to the short duration of most trips, it may be necessary to periodically use a battery charger to fully charge your battery. If you do not plan to use your trailer for an extended period of time, remove the battery from your trailer, insure that it is fully charged, and store it in a dry, climate controlled area.

# Trails West®

---

## **12 Volt Outlet**

This outlet is located in the wiring access panel between the ceiling and wall of your tack/dressing room on gooseneck models or in the front of the battery storage/seat on bumper pull models. Assuming your battery is fully charged, this outlet will operate any accessory that requires 12-volt service.

## **Pre-Wire for After Market Air Conditioner Installation**

The pre-wire package makes installation of an after market air conditioner relatively simple. This package includes: an exterior outlet to connect the trailer to a 110 volt power source, 14x14 crank up roof vent (to be removed when air conditioner is installed) and wiring from the exterior outlet to the roof vent (20 amp circuit breaker included). **We recommend installation of after market air conditioning be done by your dealer or other qualified technician.**

## **Factory Installed Air Conditioner**

Use and maintain per air conditioner manufacturer's specifications.

## **Factory Installed Awning**

Use and maintain per awning manufacturer's specifications.

## **Maintenance**

Given proper and regular maintenance, your trailer will give you many years of reliable, trouble free service. Listed below are some general guidelines that should be followed in the maintenance of your trailer.

### **Paint**

Your trailer was painted using the finest automotive products and technology available. Maintain the finish of your trailer by washing and waxing it on a regular basis. Any chips or scratches in the paint should be touched up as soon as possible to prevent the damaged area from becoming larger. Never leave salt residue on your trailer for extended periods of time. Thoroughly wash your trailer as soon as possible after it has been pulled on salted roads. Rust streaking from concealed joints can occur. These joints are left unsealed allowing the joint to "breathe" rather than sealing them, trapping moisture. Using a good grade automotive wax on your trailer will minimize or eliminate this streaking.

# Trails West®

---

## **Tires**

Periodically check and maintain the air pressure, as indicated on your trailer's tires. Visually inspect each tire for wear or damage on a regular basis.

## **Floor**

The floor of your trailer should be cleaned periodically as animal waste can be detrimental to floor boards and rubber mats. To clean the floor, remove the rubber mats (if equipped) and wash both sides. With the mats removed, wash the floor boards. Allow the mats and floor boards to dry completely before re-installing the floor mats. Any further treatment to the floor boards is unnecessary.

## **Hinges and Latches**

Door, gate and divider hinges and latches should be cleaned and lubricated periodically to insure smooth, proper operation. We suggest using a multipurpose lubricant such as WD-40 or a silicone spray.

## **Component Parts**

There are many component parts used on your trailer that are not produced by Trails West. Maintenance information of these components is specified by their respective manufacturers and is included with your warranty information packet. If you have questions or concerns regarding the maintenance of your trailer and its component parts, consult your dealer.

## Trailer Electrical Connector Plug Diagram

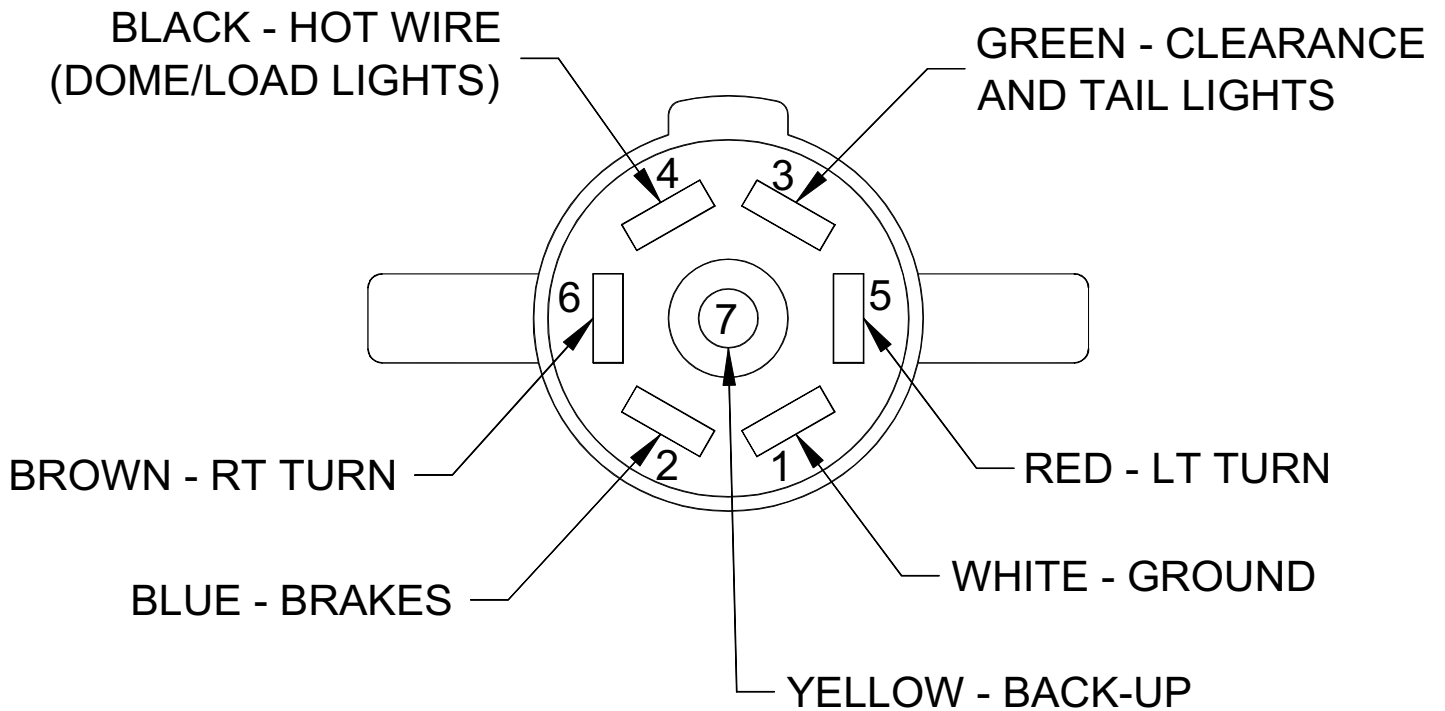

## GLOSSARY OF TIRE TERMINOLOGY

**Bead**

The part of the tire that is made of steel wires, wrapped or reinforced by ply cords and that is shaped to fit the rim.

**Bead Separation**

This is the breakdown of the bond between components in the bead.

**Bias ply tire**

A pneumatic tire in which the ply cords that extend to the beads are laid at alternate angles substantially less than 90 degrees to the centerline of the tread.

**Carcass**

The tire structure, except tread and sidewall rubber which, when inflated, bears the load.

**Chunking**

The breaking away of pieces of the tread or sidewall.

**Cold inflation pressure**

The pressure in the tire before you pull your trailer.

**Cord**

The strands forming the plies in the tire.

**Cord separation**

The parting of cords from adjacent rubber compounds.

**Cracking**

Any parting within the tread, sidewall, or inner liner of the tire extending to cord material.

**CT**

A pneumatic tire with an inverted flange tire and rim system in which the rim is designed with rim flanges pointed radially inward and the tire is designed to fit on the underside of the rim in a manner that encloses the rim flanges inside the air cavity of the tire.

**Curb weight**

The weight of a motor vehicle with standard equipment.

**Extra load tire**

A tire designed to operate at higher loads and at higher inflation pressures than the corresponding standard tire.

**Groove**

The space between two adjacent tread ribs.

**Innerliner**

The layer(s) forming the inside surface of a tubeless tire that contains the inflating medium within the tire.

**Innerliner separation**

The parting of the innerliner from cord material in the carcass.

**Intended outboard sidewall**

The sidewall that contains a white-wall, bears white lettering or bears manufacturer, brand, and/or model name molding that is higher or deeper than the same molding on the other sidewall of the tire or the outward facing sidewall of an asymmetrical tire that has a particular side that must always face outward when mounted on a vehicle.

**Light truck (LT) tire**

A tire designated by its manufacturer as primarily intended for use on lightweight trucks or multipurpose passenger vehicles.

**Load rating**

The maximum load that a tire is rated to carry for a given inflation pressure.

**Maximum load rating**

The load rating for a tire at the maximum permissible inflation pressure for that tire.

**Maximum permissible inflation pressure**

The maximum cold inflation pressure to which a tire may be inflated.

**Maximum loaded vehicle weight**

The sum of curb weight, accessory weight, vehicle capacity weight, and production options weight.

**Measuring rim**

The rim on which a tire is fitted for physical dimension requirements.

**Non-pneumatic rim**

A mechanical device which, when a non-pneumatic tire assembly incorporates a wheel, supports the tire, and attaches, either integrally or separately, to the wheel center member and upon which the tire is attached.

**Non-pneumatic spare tire assembly**

A non-pneumatic tire assembly intended for temporary use in place of one of the pneumatic tires and rims that are fitted to a passenger car in compliance with the requirements of this standard.

**Non-pneumatic tire**

A mechanical device which transmits, either directly or through a wheel or wheel center member, the vertical load and tractive forces from the roadway to the vehicle, generates the tractive forces that provide the directional control of the vehicle and does not rely on the containment of any gas or fluid for providing those functions.

**Non-pneumatic tire assembly**

A non-pneumatic tire, alone or in combination, with a wheel or wheel center member, which can be mounted on a vehicle.

**Open splice**

Any parting at any junction of tread, sidewall, or innerliner that extends to cord material.

**Outer diameter**

The overall diameter of an inflated new tire.

**Overall width**

The linear distance between the exteriors of the sidewalls of an inflated tire, including elevations due to labeling, decorations, or protective bands or ribs.

**Ply**

A layer of rubber-coated parallel cords.

**Ply Separation**

A parting of rubber compound between adjacent plies.

**Pneumatic tire**

A mechanical device made of rubber, chemicals, fabric and steel or other materials, that, when mounted on an automotive wheel, provides the traction and contains the gas or fluid that sustains the load.

**Production options weight**

The combined weight of those installed regular production options weighing over 2.3 kilograms (5 lbs.) in excess of those standard items which they replace, not previously considered I curb weight or accessory weight.

**Radial ply tire**

A pneumatic tire in which the ply cords that extend to the beads are laid at substantially 90 degrees to the center line of the tread.

**Recommended inflation pressure**

This is the inflation pressure provided by the vehicle manufacturer on the Tire Information label and on the Certification/VIN tag.

**Reinforced tire**

A tire designed to operate at higher loads and at higher inflation pressures than the corresponding standard tire.

**Rim**

A metal support for a tire or a tire and tube assembly upon which the tire beads are seated.

**Rim diameter**

This means the nominal diameter of the bead seat.

**Rim size designation**

This means the rim diameter and width.

**Rim type designation**

This means the industry of manufacturer's designation for a rim by style or code.

**Rim width**

This means the nominal distance between rim flanges.

**Section width**

The linear distance between the exteriors of the sidewalls of an inflated tire, excluding elevations due to labeling, decoration, or protective bands.

**Sidewall**

That portion of a tire between the tread and bead.

**Sidewall separation**

The parting of the rubber compound from the cord material in the sidewall.

**Test rim**

The rim on which a tire is fitted for testing, and may be any rim listed as appropriate for use with that tire.

**Tread**

That portion of a tire that comes into contact with the road.

**Tread rib**

A tread section running circumferentially around a tire.

**Tread separation**

Pulling away of the tread from the tire carcass.

**V Treadwear indicators (TWI)**

The projections within the principal grooves designed to give a visual indication of the degrees of wear of the tread.

**Vehicle capacity weight**

The rated cargo load.

**Vehicle maximum load on the tire**

The load on an individual tire that is determined by distributing to each axle its share of the maximum loaded vehicle weight and dividing by two.

**Vehicle normal load on the tire**

The load on an individual tire that is determined by distributing to each axle its share of the curb weight, accessory weight, and normal occupant weight (distributed in accordance with Table I of CRF 49 571.110) and dividing by 2.

**Weather side**

The surface area of the rim not covered by the inflated tire.

**Wheel center member**

In the case of a non-pneumatic tire assembly incorporating a wheel, a mechanical device which attaches, either integrally or separably, to the non-pneumatic rim and provides the connection between the non-pneumatic rim and the vehicle; or, in the case of a non-pneumatic tire assembly not incorporating a wheel, a mechanical device which attaches, either integrally or separably, to the non-pneumatic tire and provides the connection between tire and the vehicle.

**Wheel holding fixture**

The fixture used to hold the wheel and tire assembly securely during testing.

#### Reporting Safety Defects

If you believe that your vehicle has a defect that could cause a crash or could cause injury or death, you should immediately inform the National Highway Traffic Safety Administration (NHTSA) in addition to notifying Trails West Manufacturing of Idaho, Inc.

If NHTSA receives similar complaints, it may open an investigation, and if it finds that a safety defect exists in a group of vehicles, it may order a recall and remedy campaign. However, NHTSA cannot become involved in individual problems between you, your dealer, or Trails West Manufacturing of Idaho, Inc.

To contact NHTSA, you may either call the Vehicle Safety Hotline toll-free at 1-888-327-4236 (TTY: 1-800-424-9153), go to <http://www.safercar.gov>; or write to:

Administrator

NHTSA

1200 New Jersey Avenue S.E.

Washington, DC 20590

You can also obtain other information about motor vehicle safety from <http://www.safercar.gov>.

Reporting Safety Defects

# BREAKAWAY SWITCH INSTALLATION INSTRUCTIONS

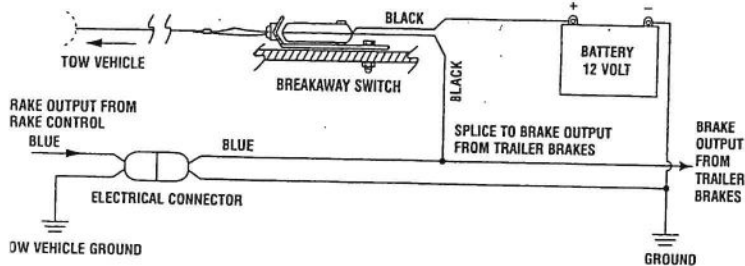

**READ THIS FIRST:**  
Read and follow all instructions carefully before installing or operating the Breakaway Switch. Keep these instructions for future reference.

## Important Facts to Remember

**ATTENTION INSTALLER:** Please give this sheet to consumer upon completion of installation.

**SAFETY ITEM:** Solder all wire connections.

Check condition of battery prior to each trip.

**WARNING** Disconnect trailer plug before testing breakaway unit. Failure to do so will result in severe damage to electronic brake control.

**WARNING** Check your breakaway system periodically to insure that wiring and connections are secure. A short or an open circuit can result in a no-brake condition.

For optimal performance, it is recommended that breakaway devices be replaced every 3-5 years.

For Technical Assistance and Warranty Information call: 1-888-785-5832 or [www.tekonsha.com](http://www.tekonsha.com)

## Installation Guide

1. Mount Battery Case securely to frame, jack post or other suitable location on trailer with Breakaway Switch Cable towards tow vehicle.
2. **WARNING** Switch location should be selected to ensure unobstructed line of pull in event of vehicle separation.
3. Bolt breakaway switch bracket to frame of trailer or battery case bracket using 1/4" bolt and lock nut or (2) 1/4" jam nuts. (Bolt and nuts not included in kit.)
4. **WARNING** Do not over tighten bolt. Switch must be able to pivot.
5. Check and install battery.
6. Wire per schematic. Properly insulate all connections.
7. Attaching to tow vehicle: Attach Breakaway Switch Cable to tow vehicle frame being certain the cable does not drag on the ground and no strain or restriction is placed on the cable.
8. **WARNING** Do not hook cable to safety chain loop or hitch ball.

# CONTACTEUR DE RUPTURE D'ATTELAGE DIRECTIVES D'INSTALLATION

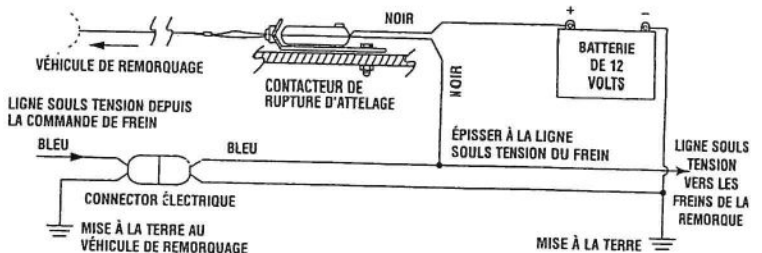

**LISEZ CECI EN PREMIER:**  
Lisez et suivez minutieusement toutes les instructions avant de monter ou utiliser l'interrupteur de dérive. Conservez ces instructions pour usage ultérieur.

## Faits importants à garder en mémoire

1. **ATTENTION INSTALLATEUR:** Prière de remettre cette fiche au consommateur une fois l'installation terminée.
2. **MESURE DE SÉCURITÉ:** Souder toutes les connexions de fil.
3. Vérifier l'état de la batterie avant chaque voyage.
4. **AVERTISSEMENT** Détacher la fiche de la remorque avant de faire l'essai de l'unité de détachement. Le non-détachement risquerait de causer des dommages graves à la commande électronique de frein.
5. **AVERTISSEMENT** Vérifiez périodiquement votre dispositif de rupture d'attelage afin de vous assurer de la sûreté du câblage et des connexions. Un court-circuit ou un circuit ouvert peut engendrer une condition de non-fonctionnement des freins.
6. Pour s'assurer du meilleur rendement, il est recommandé de remplacer les dispositifs de freinage automatique tous les 3 à 5 ans.
7. Pour assistance technique et informations concernant la garantie, prière d'appeler le 1-888-785-5832 ou [www.tekonsha.com](http://www.tekonsha.com).

## Guide d'installation

1. Montez solidement le boîtier de batterie sur le châssis, le montant du vérin ou un autre endroit approprié sur la remorque, en orientant le cordon de l'interrupteur vers le véhicule de remorquage.
2. **AVERTISSEMENT** L'emplacement de l'interrupteur doit être sélectionné de manière à assurer une ligne de traction non obstruée dans l'hypothèse de la séparation du véhicule.
3. Boulonner le support de l'interrupteur de détachement au châssis de la remorque ou au support du boîtier de batterie à l'aide d'un boulon de 1/4 po et d'un contre-écrou ou de 2 écrous de blocage de 1/4 po. (Le boulon et les écrous ne sont pas compris dans le nécessaire.)
4. **AVERTISSEMENT** Ne pas serrer le boulon excessivement. L'interrupteur doit pouvoir pivoter.
5. Vérifier et poser la batterie.
6. Câbler conformément au schéma de câblage. Isoler adéquatement toutes les connexions.
7. Fixation au véhicule de remorquage : Attachez le cordon au châssis du véhicule de remorquage en vous assurant qu'il ne traîne pas sur le sol et qu'il ne subisse aucune tension ou restriction.
8. **AVERTISSEMENT** Ne pas accrocher le câble à la boucle de la chaîne de sûreté ni à la balle d'attelage.

1: 5064015 REV G 07/03

# INTERRUPTOR DE DESENGANCHE INSTRUCCIONES DE INSTALACION

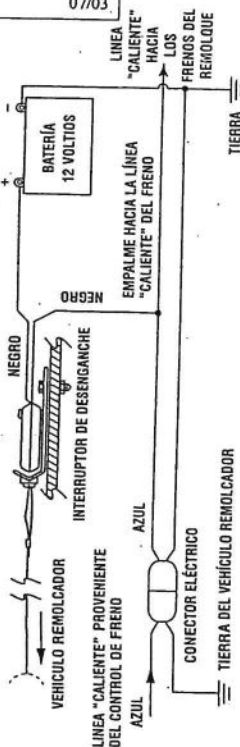

**LEA ESTO PRIMERO:**  
Lea y siga todas las instrucciones cuidadosamente antes de instalar u operar el interruptor de separación. Conserve estas instrucciones para uso futuro.

## Hechos importante para recordarr

1. **ATENCIÓN INSTALADOR:** Por favor entregue esta hoja al consumidor para el proceso de instalación.
2. **ARTÍCULO DE SEGURIDAD:** Suelde todas las conexiones del cable.
3. Revise la condición de la batería antes de cada viaje.
4. **ADVERTENCIA** Desconecte la clavija del remolque antes de probar la unidad de desenganche. El no hacerlo causará daños muy perjudiciales al control de freno electrónico.
5. **ADVERTENCIA** Inspeccione periódicamente su desenganche para asegurar que el cableado y las conexiones están aseguradas. Un corto circuito o un circuito abierto podría resultar en la falla del freno.
6. Para obtener un rendimiento óptimo, se recomienda que los dispositivos de desenganche se cambien de cada 3 a 5 años.
7. Para obtener asistencia técnica e información de la garantía llame al: 1-888-785-5832 o [www.tekonsha.com](http://www.tekonsha.com).

## Guía de instalación

1. Instale la caja de la batería firmemente al bastidor, poste del receptáculo u otra ubicación adecuada en el remolque con el cable interruptor de separación hacia el vehículo de remolque.
2. **ADVERTENCIA** Se debe seleccionar el sitio del interruptor asegurándose de que no haya una línea obstruida que se pueda estirar en caso de la separación del vehículo.
3. Atornille el soporte del interruptor de desenganche al armazón del remolque o al soporte del armazón de la batería utilizando un tornillo de 1/4 de pulg. y una tuerca de sujeción o 2 contratuercas de 1/4 de pulg. (Tornillo y tuercas no se incluyen con el equipo.)
4. **ADVERTENCIA** No apriete demasiado el tornillo. El interruptor debe poder pivotar.
5. Revise e instale la batería.
6. Coloque el cableado guiándose con el diagrama esquemático. Aísle correctamente todas las conexiones.
7. Unión con el vehículo de remolque: Una el cable interruptor de separación al bastidor del vehículo de remolque verificando que el cable no se arrastre por el piso y no esté tensionado o restringido.
8. **ADVERTENCIA** No enganche el cable a la curva de la cadena de seguridad ni a la estera de enganche.

# RB Rolled Rubber Product Limited Warranty

- 1.0 RB Rubber Products, Inc.'s rolled rubber products are guaranteed to be free of manufacturing defects in material and workmanship for 5 years ("Warranty Period"). If there are defects in material and workmanship during the Warranty Period, RB Rubber Products, Inc. Will replace or repair the mats, as described herein, at no cost to the owner/end-user. Should defects in material or workmanship be found, it is the owner's responsibility to contact RB Rubber Products, Inc. through the point of purchase or directly, as described below. This warranty does not cover dissatisfaction or problems or other damage to the materials due to or as a result of:
- improper installations and/or improper maintenance;
  - fading due to sunlight (Outdoor exposure, abrasions, and ultra-violet rays may cause normal change in the surface color and is not considered a defect under this warranty);
  - shading (color variation) of individual pieces due to natural rubber variations;
  - use of harsh and acidic chemicals, acidic foods and abrasive chemicals;
  - water spotting, petroleum adhesives or floor sealants or abuse;
  - color variation between samples and/or printed illustrations and actual product;
  - wear or product degradation expected from the use or environment of installation;
  - chewing, clawing or other animal destruction;
  - exposure to chlorine, solvents, acids, or other harmful chemicals; or
  - acts of negligence, misuse, or willful or accidental external influences including, but not limited to, vandalism, riot, or acts of war.
- \*\*\* Proof of Purchase is Required \*\*\*
- 1.1 The warranty is limited to the repair or replacement of products of RB Rubber Products, Inc. which are shown to be defective. The owner/end-user agrees not to advance any claim for any other measure of damage or loss. RB Rubber Products, Inc. shall not be liable for installation, disassembly, removal, disposal, return shipping, or other similar costs.
- 1.2 RB Rubber Products, Inc. shall not be liable for any damage, loss or claim whatsoever unless:
- 1.2.1 The manufacturer is notified in writing within fifteen (15) days of any occurrence which might give rise to a claim;
  - 1.2.2 The owner/end-user has obtained written authorization from RB Rubber Products, Inc. prior to making any repairs or alterations on or through the surface which may affect the integrity of the materials;
  - 1.2.3 RB Rubber Products, Inc. is first permitted to inspect the allegedly defective product or cause of the alleged loss, damage or claim;
  - 1.2.4 The material is installed according to the written instructions provided by RB Rubber Products, Inc. and used only as intended by RB Rubber Products, Inc.
- 1.3 If, after inspection, RB Rubber Products, Inc. determines that there has been a material defect in the product within the Warranty Period described in Paragraph 1.0, the liability of RB Rubber Products, Inc. and the remedy of the owner/end-user shall be limited, at the sole option of RB Rubber Products, Inc. to either: (a) delivery of repair or replacement material for the impacted area, or (b) credit to be applied towards the purchase of new material. The value of either remedy shall be pro-rated upon the remaining months of unexpired warranty as determined by the manufacturer. The maximum pro-rated value of either remedy shall in no case exceed the original purchase price.

## Limitation of Warranty:

- THERE IS NO WARRANTY OF MERCHANTABILITY OR FITNESS FOR A PARTICULAR PURPOSE, NOR ANY OTHER WARRANTIES WHICH EXTEND BEYOND THE DESCRIPTION ON THE FACE HEREOF.*
- RB RUBBER PRODUCTS, INC. SHALL NOT BE LIABLE FOR ANY INCIDENTAL, CONSEQUENTIAL OR OTHER DAMAGES.*
- THE REMEDIES STATED HEREIN ARE THE SOLE AND EXCLUSIVE REMEDIES FOR ANY CLAIM OR DAMAGES.*
- NO AGENT OR REPRESENTATIVE OF RB RUBBER PRODUCTS, INC. HAS ANY EXPRESS OR IMPLIED AUTHORITY TO MAKE ANY REPRESENTATION, PROMISE OR GUARANTEE NOT STATED HEREIN.*

## Disclaimer:

- Recycled rubber, as with any recycled product, can vary. Tolerances in thickness and width have been made as stringent as is possible, but some variance is to be expected. Rubber's nature is to expand and contract with changes in temperature and humidity.*
- RB rolled rubber product is not to be used in any manner or for any purpose not expressly identified by RB Rubber Products, Inc.*



Recycled rubber products leader since 1985

800-525-5530 [www.rbrubber.com](http://www.rbrubber.com)



state wide  
aluminum, inc

#### LIMITED WARRANTY

Statewide Aluminum warrants to manufactures using its products or items they manufacture for one year from the original date of purchase, that its windows and doors are free from defects of material and workmanship. Statewide Aluminum's obligation hereunder is expressly limited to providing a replacement window, door, or replacement components, as the case may be, and further to reimbursing manufacturers for one hour of market labor for the installation of the replacement window, door or components.

This warranty does not cover the screen on windows. Statewide Aluminum limits any warranty on the screen to thirty days from the original date of purchase.

This warranty shall not apply to products, which have been altered or repaired outside of the Statewide Aluminum factory. This warranty does not apply to any product, which has been improperly maintained or abused in any way. Since part of this product involves glass, which is susceptible to breakage from many forms of misuse, this warranty will not apply to the breaking of the glass.

THIS WARRANTY IS IN LIEU OF ALL OTHER WARRANTIES, EXPRESS OR IMPLIED, AND WITHOUT LIMITING THE GENERALITY OF THE FOREGOING PHRASE, LIMITS AND IMPLIED WARRANTY OF FITNESS OR MERCHANTABILITY TO THE DURATION OF THIS EXPRESS WARRANTY.

IN NO EVENT WILL STATEWIDE ALUMINUM BE LIABLE FOR LOST PROFITS OR OTHER CONSEQUENTIAL DAMAGES OR ANY CLAIM BY ANY OTHER PARTY OTHER THAN THE ORIGINAL PURCHASER OF THE PRODUCTS.

In the replacement of this product, Statewide Aluminum will not be liable for transporting the replacement product to the customer.

The customer agrees to make this warranty available to consumers prior to the sale of the item incorporating the product covered by this warranty. The customer also undertakes to fully advise the consumer of what steps must be taken by the consumer to obtain the benefits of this warranty, and also fully advise the consumer of the limitations and exclusions covered by this warranty. Wind and road noise may be an inherent consequence of sliding windows, and its presence is not a defect that would be covered by this warranty.

Some states do not allow limitations on how long an implied warranty lasts, so the above limitation may not apply to you. Some states do not allow the exclusion or limitation of incidental or consequential damages, so the above limitation and exclusion may not apply to you. This warranty gives you specific legal rights and you may also have other rights which vary from state to state.

PURCHASING FAX 219/262-0892 • P.O. BOX 987 • TELKHART, IN 46515-0987  
ACCOUNTING FAX 219/262-5032 • SALES FAX 219/262-4125 • 219/262-2594

TRUCK COVER & VAN COMPONENTS

**Read, Understand, Follow and Save These Instructions**

- Read, understand and follow all instructions before installing and using this product. Never allow anyone unfamiliar with these instructions to use this product.
- Read, understand and follow all instructions provided by the manufacturer of the product(s) on which this product will be installed.
- Installation of this product must conform to the following mounting instructions.
- Save these instructions for use as a reference in the future.

**WARNING**

**Failure to follow these warnings and instructions may result in property damage, serious bodily injury, and/or death.**

- Purchaser/owner must ensure that product is installed according to these instructions. Purchaser/owner must not alter or modify the product.
- Operator and bystanders should never position any body part under any portion of this product or the load being supported.
- Do not allow children to play on or around this product or the load being supported.
- Weigh your trailer plus added load. Do not exceed the lesser of coupler, hitch, vehicle, ball, or trailer weight ratings (including load).
- Use only a 2 5/16" ball rated equal to or greater than the capacity of this coupler. If uncertain, contact Cequent Trailer Products at 800-604-9466 or www.cequentgroup.com
- Always secure load, vehicle and trailer (by blocking wheels) before latching/unlatching coupler.
- All hardware must be torqued to 125 ft. lbs. minimum. Periodically check for proper torque and tighten if necessary. Check for wear on inner tube if retightening is needed.
- If equipped with a load bearing pin, it must be fully inserted through both the inner and outer tubes in order for the coupler to support its rated load.
- Do not tow unless the load bearing pin is fully inserted and retaining pin is installed.
- Do not exceed the 8" maximum extension for this gooseneck coupler. Measure the coupler extension as the difference between fully retracted and fully extended positions. Couplers with properly installed load bearing pins and square adjustable gooseneck couplers only extend within this range.
- Keep the ball pocket, latch, and handle clean.
- All welding must be performed by an AWS certified welder.
- This product rated according to SAE J2638.

**Before Towing:**

- Check vehicle, hitch ball and coupler for signs of wear or damage. Ensure that the coupler opens, closes, and the handle springs closed when released.
- Replace bent, broken, or worn parts before using this product.
- Ensure that the hitch ball is fully seated in the coupler ball pocket and the latch is closed.
- Make sure that the trailer safety chains are properly connected to the towing vehicle and trailer.
- Make sure that all trailer lighting is hooked up and working properly.

**Installation Instructions**

**Warning: Failure to follow all installation instructions could result in coupler failure**

Before mounting the coupler confirm that there will be no interference from the tow vehicle, tongue, ground, and any other mounted accessories while stationary or in motion. The set bolt(s) must be facing the towing vehicle. Before installing, check for interference in extended and retracted positions. Check for interference again after installation is complete. Weld size, gusseting requirements, coupler height, and orientation are dependant on trailer design and customer requirements, however, the outer tube must be supported completely by attaching gussets as low as possible to the outer tube. Avoid heat damage to coupler during welding, and do not weld over or near any holes or hardware on the coupler. All welding must be performed by an AWS certified welder. The outer tube must be rigidly attached to the trailer in order for the coupler to support its maximum rated load according to SAE J2638. Coupler must remain vertical after installation to ensure proper operation. After installation, check to make sure that coupler operation has not been impaired in any way. Do not use coupler if its operation has been impaired. After assembly and painting, but prior to being used, any enclosed labels must be affixed to the coupler and pre-mask removed.

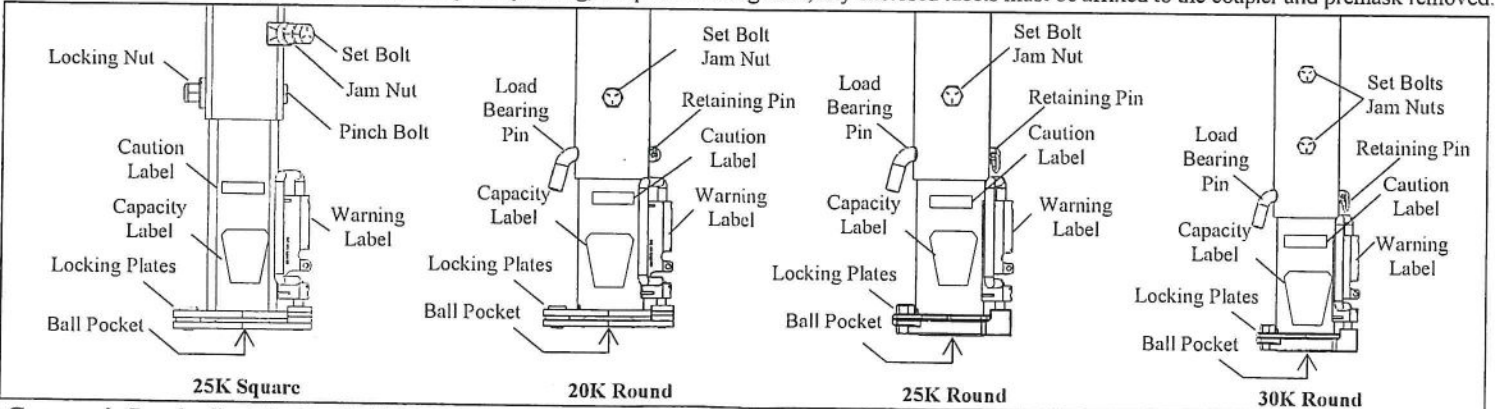

**Gooseneck Coupler Installation Guidelines:**

- 1) Be sure that the coupler will reach the towing vehicle to couple with the hitch ball while the load bearing pin is installed properly, or within the extension of the coupler if the coupler is a square adjustable gooseneck. If equipped with a load bearing pin/pinch bolt, it must be fully inserted through both the inner and outer tubes and the retaining pin/locking nut installed in order for the coupler to support its rated load.
- 2) Tighten the set bolt(s) and nut(s) to minimize vibrations in the coupler during towing. All hardware must be torqued to 125 ft. lbs. minimum.
- 3) Do not exceed 8" maximum extension for any gooseneck coupler.

**How to Measure Extension:**

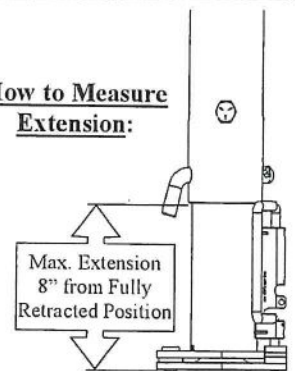

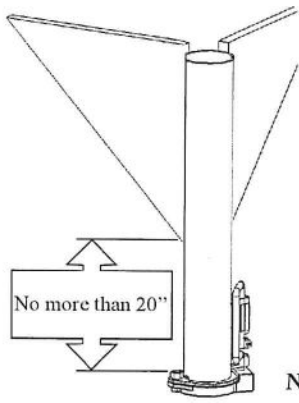

**Gusseting:**

To support the coupler's rated load, reinforcements must extend down the outer tube to within 3" above the bottom of the outer tube. The coupler must be held rigid and vertical, and must not be damaged by heat during installation.

Note: Reinforcement for non-adjustable couplers must be within 20 inches above locking plates.

**Non-adjustable coupler**

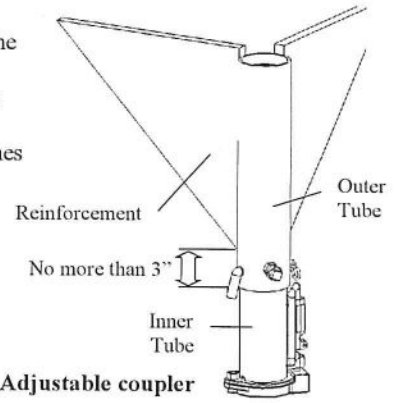

**Adjustable coupler**

**Operation**

**To Couple:**

- 1) Block trailer wheels.
- 2) Align hitch ball beneath coupler.
- 3) Set the locking pin in the open position.
- 4) Slide the locking plate into the open position and lower the trailer onto the hitch ball.
- 5) Visually check that the hitch ball is fully seated in the coupler.
- 6) Slide the locking plate into the closed position.
- 7) Set the locking pin in the closed position to close the coupler.

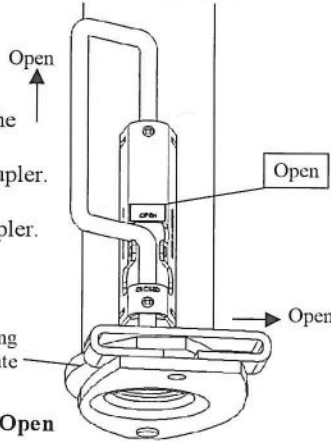

**Locking Plate Open**

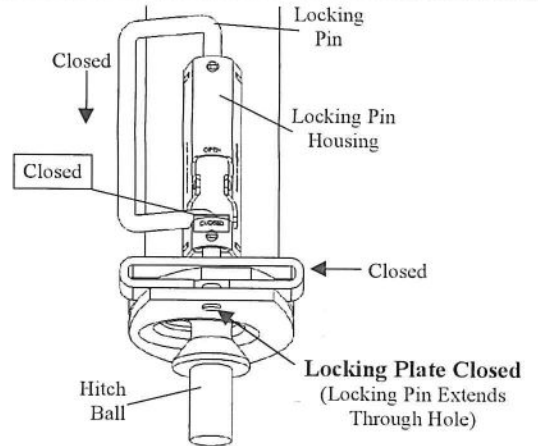

**To Uncouple:**

- 1) Block trailer wheels.
- 2) Set the locking pin in the open position.
- 3) Slide the locking plate into the open position and raise the trailer from the hitch ball.

**Maintenance**

Keep ball pocket and mechanism clean. The following procedures should be performed at least annually:

- Check hardware torque
- Grease ball pocket
- Oil pivot points with SAE 30 wt. motor oil
- Inspect retaining pin and replace if necessary

**How to Order**

Use only Cequent Trailer Products' parts. Replacement parts are available through Cequent Trailer Products' Customer Service Department, 715-693-1700 or 800-604-9466. Please specify product model number.

**Limited Three Year Warranty**

**Warranty.** Cequent Trailer Products, Inc. ("We") warrants to the original consumer purchaser ("You") that the product will be free from defects in material and workmanship for a period of three years under normal use and service, ordinary wear and tear excepted. If the product does not comply with this warranty, We will replace the product without charge to You and within a reasonable time or, at Cequent's option, refund the purchase price. This warranty is not transferable.

**Limitations on the Warranty.** The warranty does not cover the following: (a) normal wear and tear; (b) damage through abuse, neglect, misuse, or as a result of any accident or in any other manner; (c) damage from misapplication, overloading, or improper installation; (d) improper maintenance; (e) a product altered in any manner by anyone other than us.

**Obligations of Purchaser.** To make a claim, contact us at 1050 Indianhead Drive, Mosinee, WI 54455, 1-800-604-9466, identify the product, and follow the instructions that will be provided. Any returned product that is replaced or refunded becomes the property of Cequent. You will be responsible for shipping costs to us. Please retain your purchase receipt to verify date of purchase. This must be produced to honor warranty claim.

**Remedy Limits.** Repair or replacement is the purchaser's sole remedy under this or any other warranty on the product, whether express or implied. We shall not be liable for service or labor charges incurred in removing or replacing a product or any incidental or consequential damages of any kind. We expressly disclaim any implied warranty of merchantability or fitness for particular purpose after the three-year warranty period. Some states do not allow the exclusion of incidental or consequential damages or limitation of an implied warranty so the above exclusion and limitation may not apply to you.

**Legal Rights.** This warranty gives you specific legal rights, and You also may have other rights which vary from state to state. **ANY IMPLIED WARRANTY OF MERCHANTABILITY OR FITNESS FOR A PARTICULAR PURPOSE ON ANY PRODUCT SHALL BE LIMITED TO THREE YEARS FROM THE DATE OF RETAIL PURCHASE BY YOU.** Some states do not allow limitations on how long an implied warranty lasts, so the above limitation may not apply to You.

This warranty is governed by the laws of the United States of America and is void where prohibited.

**Cequent Trailer Products**  
 1050 Indianhead Dr., P.O. Box 8 Mosinee, WI 54455-0008  
 800/604-9466 715/693-1700 Fax 715/693-1799  
 TR-Sales@cequentgroup.com  
 www.cequentgroup.com

### Read, Understand, Follow and Save These Instructions

- Read, understand and follow all instructions before installing and using this product. Never allow anyone unfamiliar with the operating instructions to use this product.
- Read, understand and follow all instructions provided by the manufacturer of the product(s) that this product will be installed on.
- Installation of this product must conform to the following mounting instructions only.
- Save these instructions for use as a reference in the future.

## WARNING

Failure to follow these warnings and instructions may result in property damage, serious bodily injury, and/or death.

- Purchaser/owner must ensure that product is installed according to these instructions. Purchaser/owner must not alter or modify product.
- Operator and bystanders should never position any part of body under any portion of this product or the load being supported.
- Fully retract and/or rotate jack before towing.
- When using the drop leg, make certain the drop leg pin is fully inserted before using the jack.
- Do not allow children to play on or around this product or the load being supported.
- Secure the load, vehicle and trailer from rolling (by blocking wheels) when operating jack or coupling trailer.
- Jack capacity is limited to the lesser of the jack, footplate, or caster wheel capacity.
- Never exceed maximum rated capacity. Refer to stamped markings or decals on product to obtain rated capacity. If uncertain, contact Cequent Trailer Products at 800-604-9466 or www.cequentgroup.com
- These jacks are designed for vertical loading. Excessive side forces may cause jack failure and must be avoided.
- If this product has a pivot tube mount, make certain the pivot pin is fully inserted through both sides on the pivot tube and the pivot mount.
- If this product has a drop leg, never attempt to adjust the drop leg when the jack is under load.
- These jacks are designed for mounting to flat surfaces only.
- Keep clear of pinch point at drop leg pin. The drop leg will naturally drop or retract very quickly depending on model.
- Keep clear of holes in drop leg.
- All welding must be performed by an AWS certified welder.
- Always replace bent, broken, or worn parts before using this product.

## Installation Instructions

Before mounting the jack confirm that there will be no interference from the tow vehicle, tongue, ground, and any other mounted accessories while stationary or in motion. Before installing, check for interference in all positions including handle swing (in both gears, if applicable) and swivel positions if applicable. Check for interference again after installation is complete.

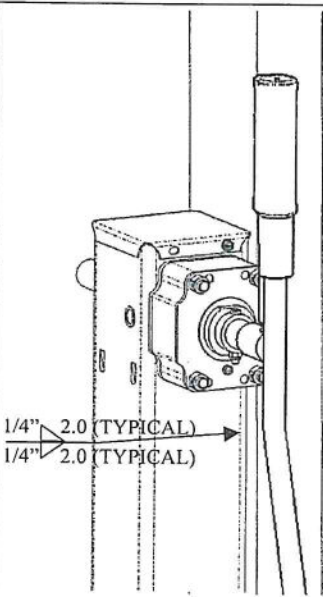

### Direct Mount to Load-Bearing Member:

- 1) All welding must be performed by an AWS certified welder.
- 2) Three 2" long 1/4" fillet welds must be placed on both sides of the jack along the contacting surface. The welds should be as far apart as possible to maximize strength under load.
- 3) If mounting in a tandem application, align the jacks carefully so they raise and lower together and share the load equally.

### 2-Speed Shift Pattern:

The jack handle moves 5/8"-3/4" while shifting. This clearance must be accounted for during installation.

- High gear is engaged when the shaft is pushed in.
- Low gear is engaged when the shaft is pulled out.

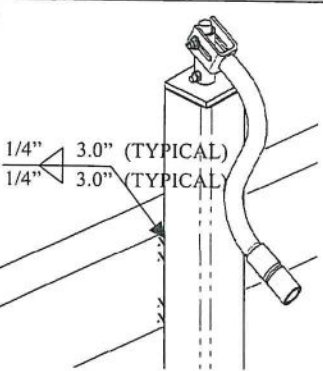
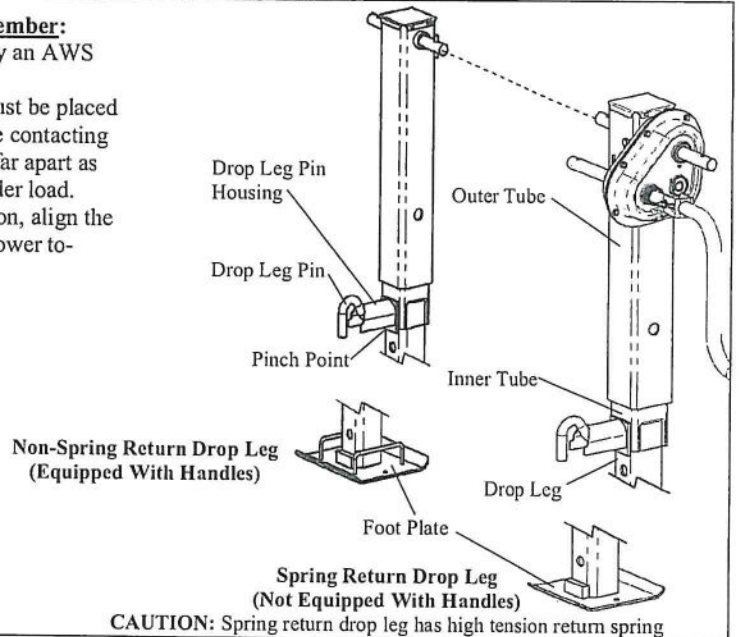

### Direct-Mount:

- 1) All welding must be performed by an AWS certified welder.
- 2) Place the jack at the desired location. Weld 3" in 2 locations on both sides of the jack using a 1/4" fillet weld.

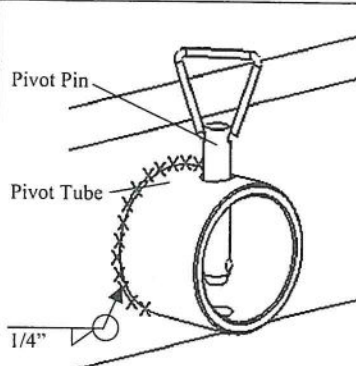

### Weld-on Pivot Tube Mounting Instructions:

- 1) All welding must be performed by an AWS certified welder.
- 2) The non-beveled side of the pivot tube is welded to the tongue.
- 3) Place the weld-on pivot tube against the tongue and weld all around with a 1/4" fillet weld. Align one set of pivot mount holes vertically.
- 4) Mate the jack to the pivot tube and secure with the supplied pin.

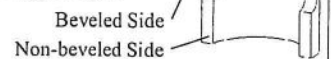

## Drop Leg Operation

### Spring Return Drop Leg Operation:

**WARNING:** Drop leg will naturally retract very quickly.

- 1) Verify that the jack is not supporting any load.
- 2) If extended, place your foot on foot plate to control the return of the drop leg.
- 3) Disengage drop leg pin by rotating to the disengaged position.
- 4) Carefully move the drop leg to the desired position using your foot.
- 5) Engage the drop leg pin by rotating it to the engaged position and into the desired adjustment hole.
- 6) Verify that the drop leg pin is fully inserted into the jack by checking for no clearance between the drop leg pin and housing. If you see clearance, you must adjust the drop leg to fully seat the pin into the hole location. You may need to lubricate the drop leg pin assembly as described in the maintenance section. If you are unable to fully seat the pin DO NOT USE.

### Non-Spring Return Drop Leg Operation:

**WARNING:** Drop leg will naturally fall.

- 1) Verify that the jack is not supporting any load.
- 2) If Retracted, grasp the handle of foot plate to control the fall of the drop leg.
- 3) Disengage drop leg pin by rotating to the disengaged position.
- 4) Carefully move the drop leg to the desired position.
- 5) Engage drop leg pin by rotating to the engaged position and into the desired adjustment hole.
- 6) Verify that the drop leg pin is fully inserted into the jack by checking for no clearance between the drop leg pin and housing. If you see clearance, you must adjust the drop leg to fully seat the pin into the hole location. You may need to lubricate the drop leg pin assembly as described in the maintenance section. If you are unable to fully seat the pin DO NOT USE.

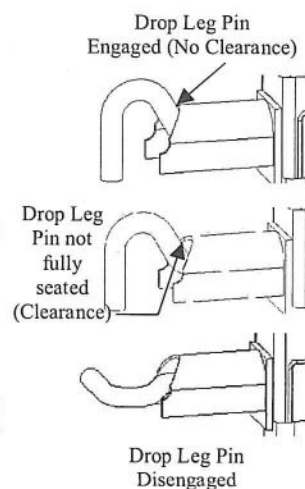

## Maintenance

The following procedures should be performed at least annually:

The gears, bushings, and screw of the jack must be kept lubricated. For side-wind models, apply a small amount of automotive grease with a grease gun at the lubrication points found on the side of the jack near the input shaft. Rotate the jack handle to distribute the grease evenly. A lightweight oil must be applied to the input shaft bushings at both sides of the jack or gearbox. For top-wind models, the screw-stem should be lubricated with a light-weight oil. If equipped, the drop leg pin and spring must be kept clean and lubricated with a lightweight oil.

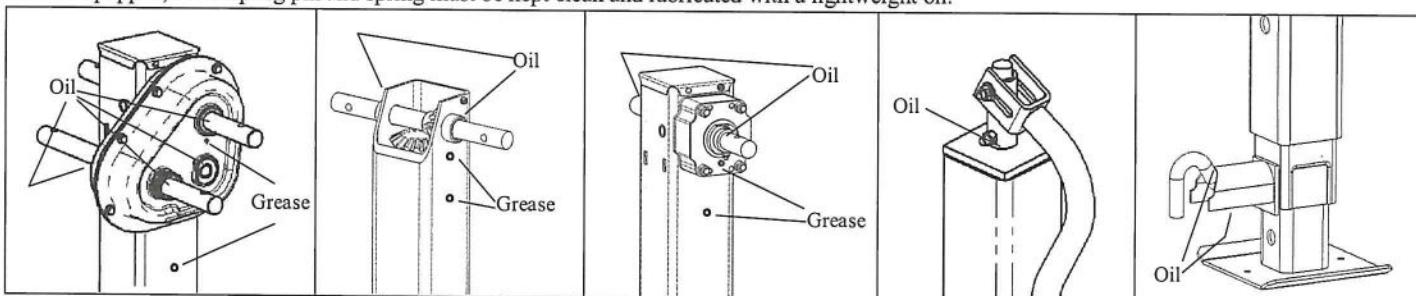

## How to Order

Use only Cequent Trailer Products' parts or parts of equal quality for repair. Replacement parts are available through Cequent Trailer Products' Customer Service Department, 715-693-1700 or 800-604-9466. Please specify product model number.

## Limited Three Year Warranty

**Warranty.** Cequent Trailer Products, Inc. ("We") warrants to the original consumer purchaser ("You") that the product will be free from defects in material and workmanship for a period of three years under normal use and service, ordinary wear and tear excepted. If the product does not comply with this warranty, We will replace the product without charge to You and within a reasonable time or, at Cequent's option, refund the purchase price. This warranty is not transferable.

**Limitations on the Warranty.** The warranty does not cover the following: (a) normal wear and tear; (b) damage through abuse, neglect, misuse, or as a result of any accident or in any other manner; (c) damage from misapplication, overloading, or improperly installed; (d) improper maintenance; (e) a product altered in any manner by anyone other than us.

**Obligations of Purchaser.** To make a claim, contact us at 1050 Indianhead Drive, Mosinee, WI, 1-800-604-9466, identify the product, and follow the instructions that will be provided. Any returned product that is replaced or refunded becomes the property of Cequent. You will be responsible for shipping costs to us. Please retain your purchase receipt to verify date of purchase. This must be produced to honor warranty claim.

**Remedy Limits.** Repair or replacement is the purchaser's sole remedy under this or any other warranty on the product, whether express or implied. We shall not be liable for service or labor charges incurred in removing or replacing a product or any incidental or consequential damages of any kind. We expressly disclaim any implied warranty of merchantability or fitness for particular purpose after the three-year warranty period. Some states do not allow the exclusion of incidental or consequential damages or limitation of an implied warranty so the above exclusion and limitation may not apply to you.

**Legal Rights.** This warranty gives you specific legal rights, and You also may have other rights which vary from state to state. **ANY IMPLIED WARRANTY OF MERCHANTABILITY OR FITNESS FOR A PARTICULAR PURPOSE ON ANY PRODUCT SHALL BE LIMITED TO THREE YEARS FROM THE DATE OF RETAIL PURCHASE BY YOU.** Some states do not allow limitations on how long an implied warranty lasts, so the above limitation may not apply to You.

This warranty is governed by the laws of the United States of America and is void where prohibited.

**Cequent Trailer Products**  
 1050 Indianhead Dr., P.O. Box 8 Mosinee, WI 54455-0008  
 800/604-9466 715/693-1700 Fax 715/693-1799  
 TR-Sales@cequentgroup.com  
 www.cequentgroup.com



# Bulldog Collar-Lok™ Couplers

## Read, Understand, Follow and Save These Instructions

Read, understand and follow all of these instructions and warnings (Instructions) before installing and using this product. Install and use this product only as specified in these instructions. Improper installation or use of this product may result in property damage, serious injury, and/or death. Never allow installation or use of this product by anyone without providing them with these instructions. You must read, understand and follow all instructions and warnings for any product(s) to which this product is used in conjunction with or installed. Save these instructions with the product for use as a reference for any future installation and use of the product.

### ⚠ WARNING

**Failure to follow these warnings and instructions may result in property damage, serious bodily injury, and/or death.**

- Purchaser/owner must ensure that product is installed according to these instructions.
- Purchaser/owner must not alter or modify the product.
- Operator and bystanders should never position any part of body under any portion of this product or the load being supported.
- Do not allow children to play on or around this product or the load being supported.
- Weigh your trailer plus added load. Do not exceed lesser of bracket, coupler, hitch, vehicle, ball, or trailer weight ratings (including load).
- Use only the proper ball for this coupler as indicated on the coupler body. If uncertain, contact Cequent Trailer Products at 800-604-9466 or www.cequentgroup.com.
- Always secure load, vehicle and trailer (by blocking wheels) before latching/unlatching coupler.
- Use caution when uncoupling as tongue may rise suddenly due to negative tongue load.
- After installing channel and/or coupler, if coupler operation has been impaired in any way, do not use it.
- Keep the ball pocket and mechanism clean. When parking or storing your trailer, keep the coupler off the ground so dirt and/or other foreign material will not build up in the coupler ball pocket.

- Do not tow if ball is not fully seated and/or coupler is not closed.
- All welding must be performed by a certified AWS welder.

#### Before Towing:

- Check vehicle, channel, hitch, hitch ball and coupler for signs of wear or damage and that the coupler handle opens and closes freely. If coupler and/or channel is deformed or damaged, replace complete coupler and bracket.
- Replace bent, broken, or worn parts before using this product.
- Close coupler securely by ensuring that the hitch ball is fully seated in the coupler ball pocket and the pin is inserted behind the collar or latch.
- Check channel hardware for wear and proper tightness. Replace bent, broken, or worn hardware. Tighten hardware to 75-100 ft. lbs. Use only grade 5 hardware.
- Make sure that the trailer safety chains are properly connected to the towing vehicle and trailer according to SAE J684.
- Make sure that all trailer lighting is hooked up and working properly.

### Installation Instructions

**Warning: Failure to follow these warnings and instructions may result in property damage, serious bodily injury, and/or death.**

Before mounting the coupler confirm that there will be no interference from the tow vehicle, tongue, ground, and any other mounted accessories while stationary or in motion. Before installing, check for interference in open and closed positions. Check for interference again after installation is complete. All welding must be performed by an AWS certified welder. The coupler must be rigidly attached to the trailer in order for the coupler to support its maximum rated load according to SAE J684. After installation, check to make sure that coupler operation has not been impaired in any way. Do not use coupler if its operation has been impaired.

- All welding must be performed by an AWS certified welder.
- If using a weld-on coupler, weld 3/16" around the interface between coupler and tongue. See illustrations below.
- Assure the coupler internal stop is butted against the end of the trailer tongue for maximum overlap.
- For bolt-on couplers, use (2) 5/8" Grade 5 through bolts with nylon locknuts, torque to 75-100 ft. lbs. Do not deform tongue or coupler.

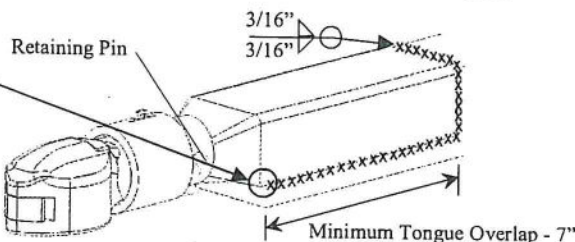
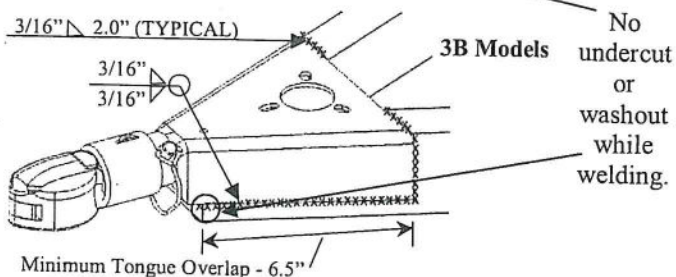
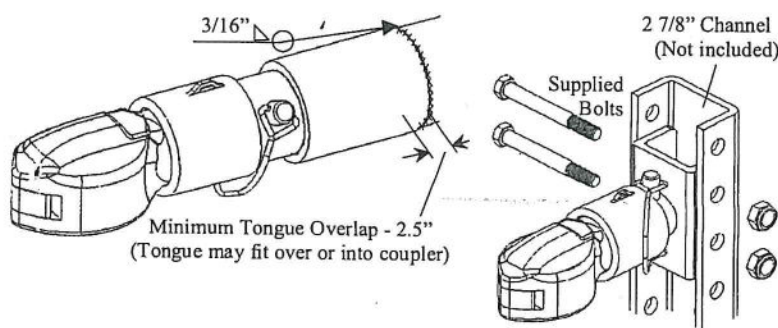
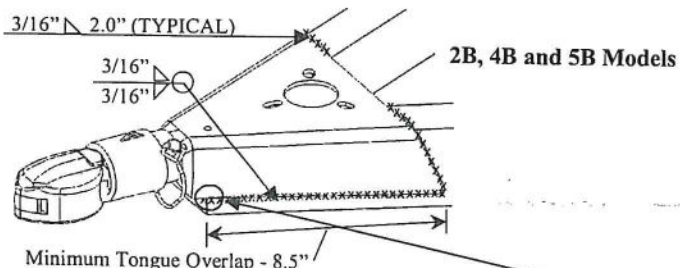
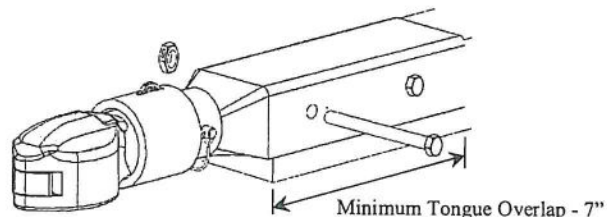

### Maintenance

Keep ball pocket and mechanism clean. The following procedures should be performed at least annually:

- Check set screw torque.
- Grease ball pocket.
- Oil pivot points with SAE 30 wt. motor oil.
- Inspect retaining pins and replace if necessary.

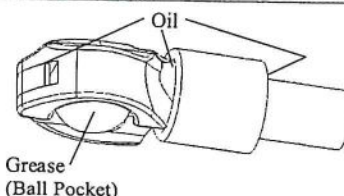
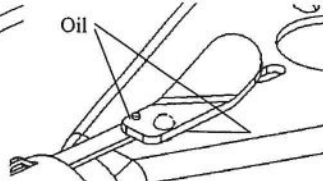
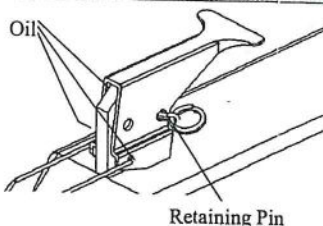

## Operation

### M-Style Coupler

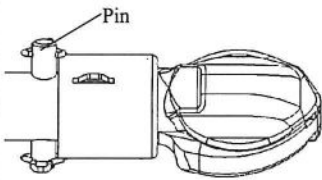

#### To Couple:

- 1) Block trailer wheels.
- 2) Align hitch ball beneath coupler.
- 3) If the coupler is closed, open it by removing the pin behind the collar and sliding the collar away from the ball pocket. Be sure the coupler cap is open and holds the collar back.
- 4) Lower the trailer onto the hitch ball.
- 5) Visually check that the hitch ball is fully seated in the coupler.
- 6) After the hitch ball is seated in the coupler, carefully close the coupler cap. Be sure the collar springs toward the ball pocket and captures the coupler cap.
- 7) Reinsert the pin behind the collar. Do not tow without pin in place.

### L-Style Coupler

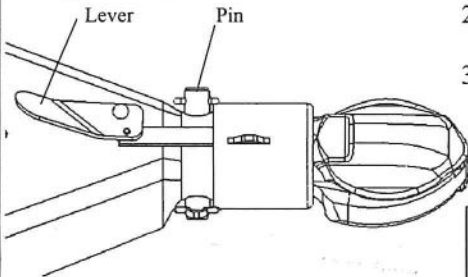

#### To Uncouple:

- 1) Block trailer wheels.
- 2) Open the coupler by removing the pin behind the collar and sliding the collar away from the ball pocket. Be sure the coupler cap is open and holds the collar back.
- 3) Raise the trailer from the hitch ball.

#### Coupler is Open Cap is Open

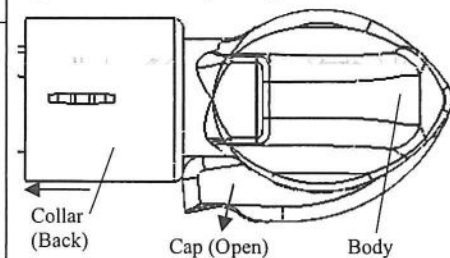

#### Coupler is Closed Collar is Capturing Cap

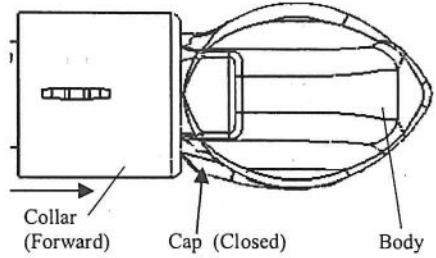

### H-Style Coupler

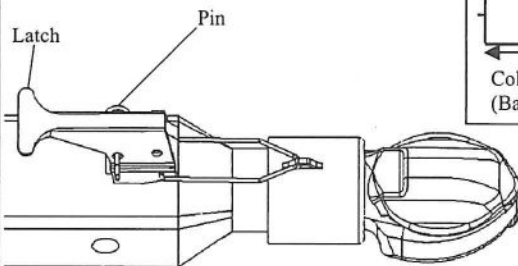

#### To Couple:

- 1) Block trailer wheels.
- 2) Align hitch ball beneath coupler.
- 3) If the coupler is closed, open it by removing the pin in the latch and lifting the latch. Be sure the coupler cap is open and holds the collar back.
- 4) Lower the trailer onto the hitch ball.
- 5) Visually check that the hitch ball is fully seated in the coupler.
- 6) After the hitch ball is seated in the coupler, carefully close the coupler cap and lower the latch. Be sure the collar springs toward the ball pocket and captures the coupler cap.
- 7) Reinsert the pin in the latch. Do not tow without pin in place.

#### To Uncouple:

- 1) Block trailer wheels.
- 2) Open the coupler by removing the pin in the latch and lifting the latch. Be sure the coupler cap is open and holds the collar back.
- 3) Raise the trailer from the hitch ball.

## How to Order

Use only Cequent Trailer Products' parts. Replacement parts are available through Cequent Trailer Products' Customer Service Department, 715-693-1700 or 800-604-9466. Please specify product model number.

## Limited Five Year Warranty

**Limited Warranty.** Cequent Trailer Products, Inc. ("We" or "Us") warrants to the original consumer purchaser only ("You") that the product will be free from material defects in both material and workmanship for a period of five years, ordinary wear and tear excepted; provided that installation and use of the product is in accordance with product instructions. There are no other warranties, express or implied, including the warranty of merchantability or fitness for a particular purpose. If the product does not comply with this limited 5 year warranty, Your sole and exclusive remedy is that We will replace the product without charge to You and within a reasonable time or, at our option, refund the purchase price. This warranty is not transferable.

**Limitations on the Warranty.** This limited warranty does not cover: (a) normal wear and tear; (b) damage through abuse, neglect, misuse, or as a result of any accident or in any other manner; (c) damage from misapplication, overloading, or improper installation, including welds; (d) improper maintenance and repair; and (e) product alteration in any manner by anyone other than Us, with the sole exception of alterations made pursuant to product instructions and in a workmanlike manner.

**Obligations of Purchaser.** To make a warranty claim, contact Us at 1050 Indianhead Drive, Mosinee, WI, 54455, 1-800-604-9466, identify the product by model number, and follow the claim instructions that will be provided. Any returned product that is replaced or refunded by Us becomes our property. You will be responsible for return shipping costs. Please retain your purchase receipt to verify date of purchase and that You are the original consumer purchaser. The product and the purchase receipt must be provided to Us in order to process Your warranty claim.

**Remedy Limits.** Repair or replacement is Your sole remedy under this limited warranty or any other warranty related to the product. We shall not be liable for service or labor charges incurred in removing or replacing a product or any incidental or consequential damages of any kind.

**Assumption of Risk.** You acknowledge and agree that any use of the product for any purpose other than the specified use(s) stated in the product instructions is at Your own risk.

**Governing Law.** This limited warranty gives You specific legal rights, and You also may have other rights which vary from state to state. This limited warranty is governed by the laws of the State of Michigan, without regard to rules pertaining to conflicts of law. The state courts located in Oakland County, Michigan shall have exclusive jurisdiction for any disputes relating to this warranty.

**Cequent Trailer Products, Inc.**  
 1050 Indianhead Dr., P.O. Box 8 Mosinee, WI 54455-0008  
 800/604-9466 715/693-1700 Fax 715/693-1799  
 TR-Sales@cequentgroup.com  
 www.cequentgroup.com  
 Made in Mexico

# Tongue Jacks



**FULTON**



## Read, Understand, Follow and Save These Instructions

Read, understand and follow all of these instructions and warnings (Instructions) before installing and using this product. Install and use this product only as specified in these instructions. Improper installation or use of this product may result in property damage, serious injury, and/or death. Never allow installation or use of this product by anyone without providing them with these instructions. You must read, understand and follow all instructions and warnings for any product(s) to which this product is used in conjunction with or installed. Save these instructions with the product for use as a reference for any future installation and use of the product.

### WARNING

**Failure to follow these warnings and instructions may result in property damage, serious bodily injury, and/or death.**

- Purchaser/owner must ensure that product is installed according to these instructions. Purchaser/owner must not alter or modify product.
- Operator and bystanders should never position any part of body under any portion of this product or the load being supported.
- Fully retract and rotate jack before towing.
- When using the drop foot or drop leg, make certain the supplied pin is fully inserted through both sides of the inner tube and the drop tube before using the jack.
- If using optional drop foot or caster, always remove drop foot or caster before towing to maximize ground clearance.
- This product is not intended to be used as a transport device for the implement it is attached to. Minimize movement of implement while jack is under load.
- Do not allow children to play on or around this product or the load being supported.
- Secure the load, vehicle and trailer from rolling (by blocking wheels) when operating jack or coupling trailer.
- Jack capacity is limited to the lesser of the jack, footplate, or caster wheel capacity.
- Never exceed maximum rated capacity. Refer to stamped markings or decals on product to obtain rated capacity. If uncertain, contact Cequent Performance Products at 1-800-632-3290 or www.cequentgroup.com.
- These jacks are designed for vertical loading. Excessive side forces may cause jack failure and must be avoided.
- Before manually moving trailer, crank to lowest position.
- If this product has a pivot tube mount, make certain the pivot pin is fully inserted through both sides on the pivot tube and the pivot mount.
- If this product is a swivel jack, lock the plunger pin into a hole in the mounting bracket before raising or lowering the tongue.
- Before installing the snap ring, inspect the snap ring groove and remove any debris. Seat the snap ring fully into the groove.
- Do not attempt to weld "Bolt-On" brackets or straps to the tongue. Special brackets are available for "Weld-On" applications.
- If this product has a drop foot or drop leg, never attempt to adjust the drop foot or drop leg when there is any load on the jack.
- If this product is a rack jack, do not raise the gear housing above inner tube.
- These jacks are not designed for mounting to round tongues.
- All welding must be performed by an AWS certified welder.
- Always replace bent, broken, or worn parts before using this product.

### Installation Instructions

**Warning: Failure to follow these warnings and instructions may result in property damage, serious bodily injury, and/or death.**

Before mounting the jack confirm that there will be no interference from the tow vehicle, tongue, ground, and any other mounted accessories while stationary or in motion. Before installing, check for interference in all positions including handle swing and swivel positions if applicable. Check for interference again after installation is complete.

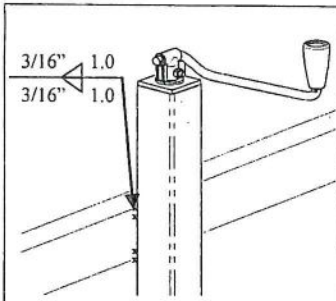

#### Direct-Mount:

The same welding instructions apply to other weld-on mounts.

- 1) All welding must be performed by an AWS certified welder.
- 2) Place the jack at the desired location. Weld 1" in 2 locations on both sides of the jack using a 3/16" fillet weld.

#### Bolt-On Mounting Bracket Instructions:

If using a bolt-on jack, assure the correct mounting hole pattern for your tongue size. The gap between the mounting bolts and the tongue is not to exceed 1/16"

- 1) Place the jack against the tongue and position the mounting straps on the opposite side of the tongue. Align the holes in the mounting bracket with the holes in the mounting straps.
- 2) Insert the 4 bolts through the mounting bracket and mounting straps. The upper bolts should rest on the top of the tongue. The lower bolts should be less than 1/16" from the bottom of the tongue.
- 3) Secure with locknuts, torque to 25 ft. lbs.
- 4) Check for clearance of handle, trailer light cables, and coupler.

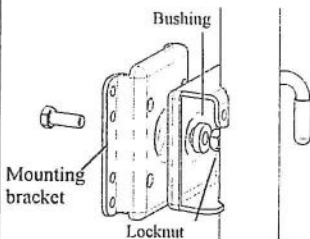

#### Snap Ring/Bolt-Thru Instructions:

- 1) To attach a snap ring model jack, place the jack bracket over the mount and place the snap ring in the groove. Seat the snap ring fully into the groove.
- 2) To attach a bolt-thru model jack, place the jack bracket into the recessed opening on the mount. Place the small end of bushing into the jack bracket and onto the bolt. Tighten locknut until there is little movement in the bushing. Note: The bolt should be installed between the trailer tongue and mount, the jack bracket will be held by the bushing between the locknut and the mount.

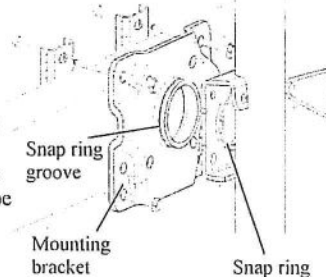

#### Bolt-on Rack Jack Instructions:

- 1) Place the gear housing on the tongue, insert supplied bolts in holes corresponding to the tongue width.
- 2) Place the mounting bracket below the tongue with the flat surface against the tongue.
- 3) Secure with locknuts, torque to 25 ft. lbs.

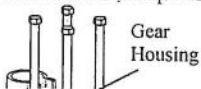

#### "A" Plate Mounting Instructions (Bolt-On or Weld-On):

A-plate jacks are designed for mounting to trailers with A-plate couplers. It is recommended to attach a bottom support plate to the bottom of the tongue.

- 1) All welding must be performed by an AWS certified welder.
- 2) If the "A" plate is separate from the jack, align the jack (and foot, if equipped) with the jack and coupler as desired before welding. Use a 3/16" fillet weld.
- 3) Bolt the jack "A" plate to the coupler. Use three 3/8-16 grade 5 bolts with washers, torque to 15-20 ft. lbs.
- 4) Weld the recommended support plate to the bottom of the trailer

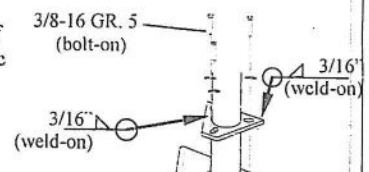

## Installation Instructions (Continued)

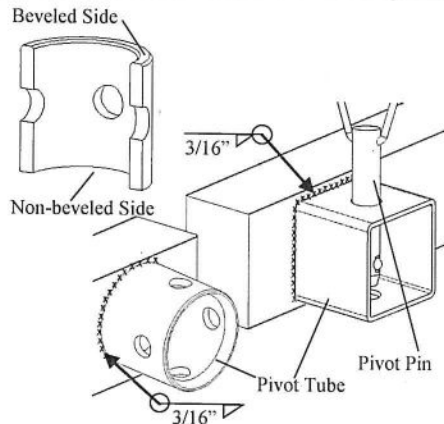
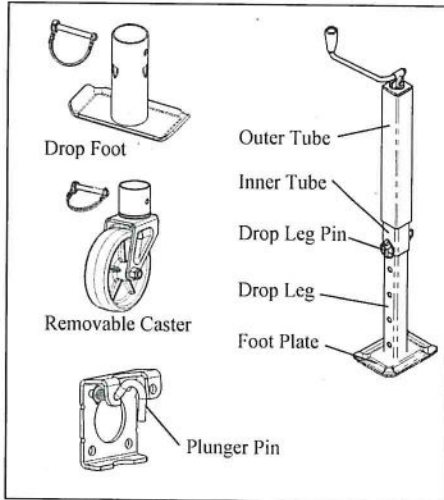

### To attach a handle assembly:

- 1) Insert the long spacer into the roller followed by the thin spacer and the bolt.
- 2) Secure to the crank stem with the nut provided.

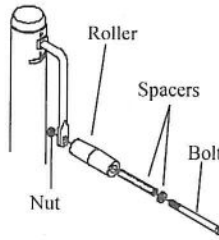

### To attach a wheel assembly:

- 1) Insert the long spacer into the wheel.
- 2) Set the wheel into the caster body and place the bolt through the caster body and wheel.
- 3) Secure with the nut provided.

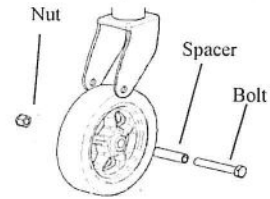

### To attach a top-wind handle assembly:

- 1) Place the washer over the screw stem and then place the handle over the screw stem.
- 2) Secure the handle to the screw stem with the bolt and nut provided.

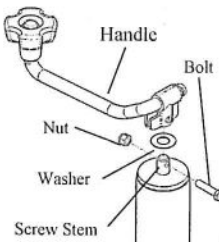

### Heavy Duty Caster:

- 1) Jack capacity limited to lesser of jack or caster.
- 2) Use 4 3/8" bolts, washers, and locknuts as shown.

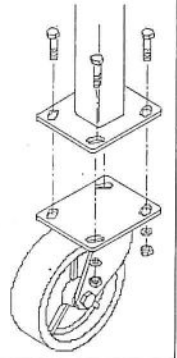

### Weld-on Pivot Tube Mounting Instructions (Round and Square Pivot Tubes):

- 1) All welding must be performed by an AWS certified welder.
- 2) The non-beveled side of the pivot tube is welded to the tongue unless otherwise specified on hardware.
- 3) Place the weld-on pivot tube against the tongue and weld all around with a 3/16" fillet weld. Align one set of pivot mount holes vertically.
- 4) Mate the jack to the pivot tube and secure with the supplied pin.

## Maintenance

The following procedures should be performed at least annually: For side-wind models, the internal gearing and bushings of the jack must be kept lubricated. Apply a small amount of automotive grease to the internal gearing by removing the jack cover, or if equipped, use a needle nose applicator or standard grease gun on the lubrication point found on the side of the jack near the crank. Rotate the jack handle to distribute the grease evenly. A lightweight oil must be applied to the handle unit at both sides of the tube for side-wind models. If equipped, the axle bolt and nut assembly of the caster wheel must also be lubricated with the same light weight oil. For top-wind models, apply a lightweight oil to the screw stem. If this product is used in a marine environment, flush the jack assembly and bushings with fresh water, and apply fresh lubricant.

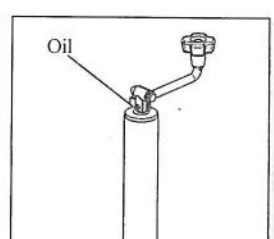
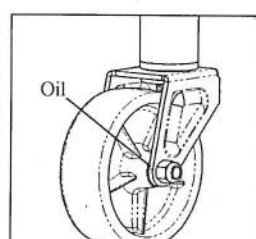
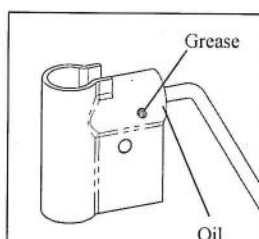
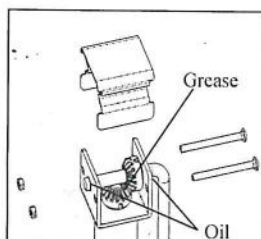
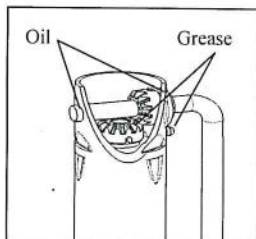

## How to Order

Use only Cequent Performance Products' parts or parts of equal quality for repair. Replacement parts are available through Cequent Performance Products' Customer Service Department, 1-800-632-3290. Please specify product model number.

## Limited Warranty

**Limited Warranty.** Cequent Performance Products, Inc. ("We" or "Us") warrants to the original consumer purchaser only ("You") that the product will be free from defects in both material and workmanship for a period of **five years for Bulldog® and Fulton® products and one year for the Pro-Series® and Reese Towpower® products**, ordinary wear and tear excepted; provided that installation and use of the product is in accordance with product instructions. There are no other warranties, express or implied, including the warranty of merchantability or fitness for a particular purpose. If the product does not comply with the applicable limited year warranty, Your sole and exclusive remedy is that We will replace the product without charge to You and within a reasonable time or, at our option, refund the purchase price. This warranty is not transferable.

**Limitations on the Warranty.** This limited warranty does not cover: (a) normal wear and tear; (b) damage through abuse, neglect, misuse, or as a result of any accident or in any other manner; (c) damage from misapplication, overloading, or improper installation, including welds; (d) improper maintenance and repair; and (e) product alteration in any manner by anyone other than Us, with the sole exception of alterations made pursuant to product instructions and in a workmanlike manner.

**Obligations of Purchaser.** To make a warranty claim, contact Us at 47912 Halyard Dr. Suite 100, Plymouth, MI 48170, 1-800-632-3290, identify the product by model number, and follow the claim instructions that will be provided. Any returned product that is replaced or refunded by Us becomes our property. You will be responsible for return shipping costs. Please retain your purchase receipt to verify date of purchase and that You are the original consumer purchaser. The product and the purchase receipt must be provided to Us in order to process Your warranty claim.

**Remedy Limits.** Repair or replacement is Your sole remedy under this limited warranty or any other warranty related to the product. We shall not be liable for service or labor charges incurred in removing or replacing a product or any incidental or consequential damages of any kind.

**Assumption of Risk.** You acknowledge and agree that any use of the product for any purpose other than the specified use(s) stated in the product instructions is at Your own risk.

**Governing Law.** This limited warranty gives You specific legal rights, and You also may have other rights which vary from state to state. This limited warranty is governed by the laws of the State of Michigan, without regard to rules pertaining to conflicts of law. The state courts located in Oakland County, Michigan shall have exclusive jurisdiction for any disputes relating to this warranty.

47912 Halyard Dr. Suite 100  
Plymouth, MI 48170 USA  
800/632-3290  
www.cequentgroup.com